

FLANGED BALL VALVES ASME CLASS 150 & 300

REDUCED BORE:

1/2" – 20" (DN 15 – 500) SERIES 7000

The Jamesbury® polymer-seated flanged ball valves provide industry leading performance and reliability. Offered in a wide variety of materials to suit an extensive range of applications these valves are designed and manufactured with all our latest technology and expertise.



Unique Sealing

The superior performance of *Jamesbury* ball valves is achieved by the unique design of the seats. The flexible lip seats exert continuous sealing pressure on the ball and automatically compensate for wear and changes in pressure and temperature, yielding positive bi-directional zero-leak shut-off. The stem seal sealing system ensures minimum emissions.

Materials

Standard products are available with carbon steel body and stainless steel trim or all stainless steel construction. Special body and trim materials such as Alloy 20, Hastelloy® C, and others are available upon request. For applications involving chemicals, acids, caustics, and steam we recommend our Xtreme® seat material, which provides superior life-cycle and sealing performance compared to virgin or filled PTFE. We can accommodate nearly any special customer or application specific requirement.

Fite-Tite® Valves

All *Jamesbury Fire-Tite* flanged ball valves are qualified to API 607 and ISO 10497. This ensures minimal leakage in the event of a fire.

CE marked

CE marked and documented product conforming to the European Pressure Equipment Directive (PED) 2014/68/EU and ATEX Directive 2014/34/EU is available as standard product.

Features And Benefits

- ❑ Robust engineering design yields leading cycle life
- ❑ Outstanding quality provides confidence
- ❑ Flexible lip seat provides bi-directional zero-leak shut-off and minimum maintenance
- ❑ Xtreme seats provide longer life and expanded pressure-temperature capability
- ❑ Patented stem seal system engineered to provide superior emissions performance (1/2" - 2")
- ❑ Live loaded stem packing enhances emissions performance and reduces maintenance (1/2" - 8")
- ❑ ISO 5211 bonnet mounting design (1/2" - 8")
- ❑ API 607 qualified
- ❑ API 608 compliance & grounding as standard (3" - 8")
- ❑ ISO 15848-1 Class BH rated (1/2" - 8")
- ❑ Standard materials meet requirements of NACE MR0103 and MR0175 (see p29 & 30)
- ❑ SIL 3 qualified

Emission-Pak® Valves

Jamesbury Emission-Pak products feature a double stem seal packing system to provide additional sealing performance for critical services. This feature is ISO 15848-1 Class AH rated.

Automated Assemblies

Valves, actuators, and accessories designed to mate together with precision ensures superior performance.

SPECIFICATIONS

Flow Data

The table at right provides flow coefficients for *Jamesbury* valves covered in this bulletin. Cv values represent the flow of water at +60°F through the valve in U.S. gallons per minute at a pressure drop of 1 psi. The metric equivalent, K_v , is the flow of water at +16°C through the valve in cubic meters per hour at a pressure drop of 1 kg/cm². To convert Cv to Kv, multiply by 0.8569.

Valve Body Ratings

These are the maximum working pressure ratings of the valve body only. The seat ratings, shown on the next page, determine the practical temperature and pressure limitations according to actual service conditions. Test pressures are recommended pressures for hydrostatic test with ball half open.

| Valve Size | | Cv |
|------------|-----|----------------|
| Inches | DN | Standard Bore |
| 1/2 | 15 | 9 |
| 3/4 | 20 | 19 |
| 1 | 25 | 45 |
| 1-1/2 | 40 | 125 |
| 2 | 50 | 165 |
| 3 | 80 | 350 |
| 4 | 100 | 550 |
| 6 | 150 | 765 |
| 8 | 200 | 1890 |
| 10 | 250 | 3900 |
| 12 | 300 | 6700 |
| 14 | 350 | 5100/5400* |
| 16 | 400 | 8100/8500* |
| 18 | 450 | 11,000/9800* |
| 20 | 500 | 16,000/13,000* |

* Class 300 long pattern

| Maximum Working Pressure, psi | | | | | | |
|-------------------------------|--------------|---------------------|----------|--------|--------------|---------------------|
| Temp °F | Class 150 | | | | Class 300 | |
| | Carbon steel | 316 Stainless steel | Alloy 20 | Monel® | Carbon steel | 316 Stainless steel |
| -20 to 100 | 285 | 275 | 230 | 230 | 740 | 720 |
| 200 | 260 | 235 | 200 | 200 | 675 | 620 |
| 300 | 230 | 215 | 190 | 190 | 655 | 560 |
| 400 | 200 | 195 | 190 | 185 | 635 | 515 |
| 500 | 170 | 170 | 170 | 170 | 600 | 480 |
| Test Pressure | 450 | 425 | 350 | 350 | 1125 | 1100 |

| Maximum Working Pressure, bar | | | | | | |
|-------------------------------|--------------|---------------------|----------|-------|--------------|---------------------|
| Temp °C | Class 150 | | | | Class 300 | |
| | Carbon steel | 316 Stainless steel | Alloy 20 | Monel | Carbon steel | 316 Stainless steel |
| -29 to 38 | 19.6 | 19.0 | 15.9 | 15.9 | 51.1 | 49.6 |
| 93 | 17.7 | 16.2 | 13.5 | 13.5 | 46.6 | 42.2 |
| 149 | 15.8 | 14.8 | 13.1 | 13.1 | 45.1 | 38.5 |
| 204 | 13.8 | 13.7 | 13.1 | 13.1 | 43.8 | 35.7 |
| 260 | 11.7 | 11.7 | 11.7 | 11.7 | 41.9 | 33.4 |
| Test Pressure | 30 | 29 | 24 | 24 | 77 | 75 |

Valve Seat Ratings

Seat ratings, indicated by solid lines in the charts on the next page, are based on differential pressure with the valve ball in the fully closed position and refer to seats only. The dotted lines indicate maximum working pressures for *WCB carbon steel* valve bodies. (Maximum working pressures of other body materials are shown in the tables above.) The combination of dotted and solid lines indicates the maximum valve rating at specific pressure and temperature conditions. Valves with PTFE, *Xtreme*, PEEK®, PFA, and UHMW polyethylene seats can be used in service to -60°F (-51°C) provided that the valve body material is suitable for such a temperature. Carbon steel valves are rated to -20°F (-29°C).

For saturated steam service, stainless steel trim is recommended at all pressures and is required above 200 psi (14 bar). See Bulletin B150-1. For more application information on seat materials, refer to Bulletin T140-1.

Xtreme Performance and Value

Xtreme seats provide longer life, expanded performance boundaries, and the greatest possible value. *Xtreme* material is unique, resulting from a technological breakthrough in our polymer research lab. The material is a proprietary fluoropolymer based blend that provides superior quarter-turn performance.

1/2" – 2" (DN 15 – 50) Standard Bore

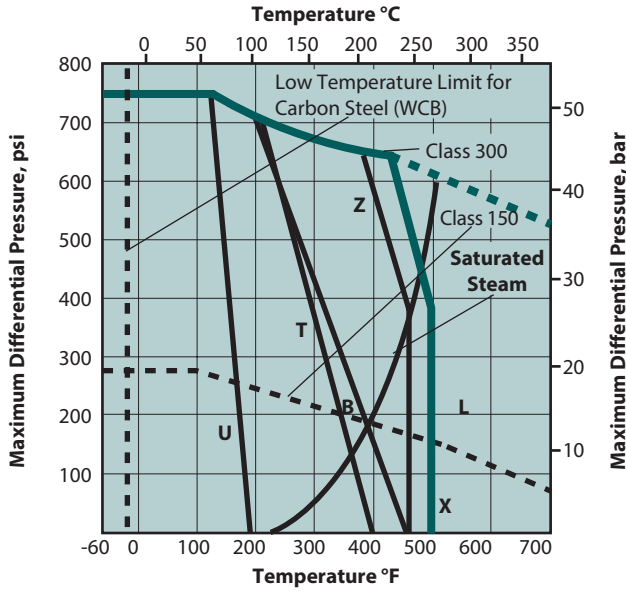

3" – 6" (DN 80 – 150) Standard Bore

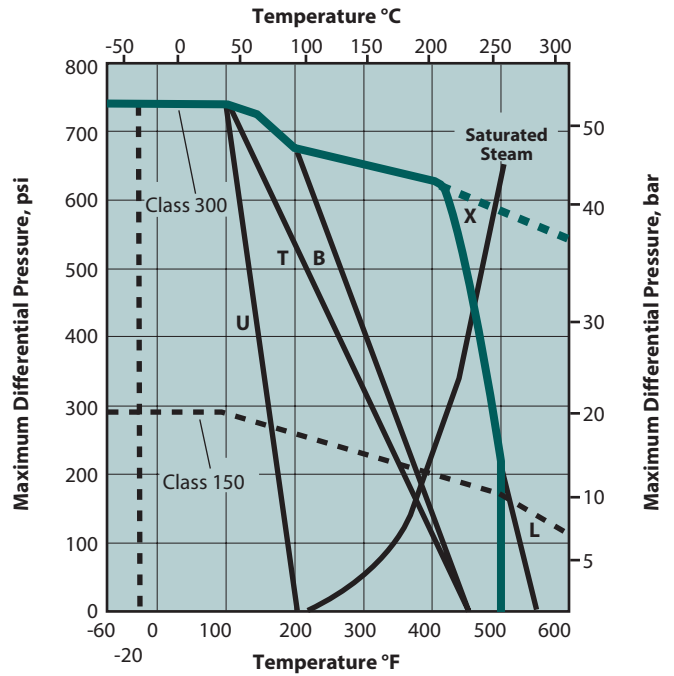

8" (DN 200) Standard Bore Non-Trunnion

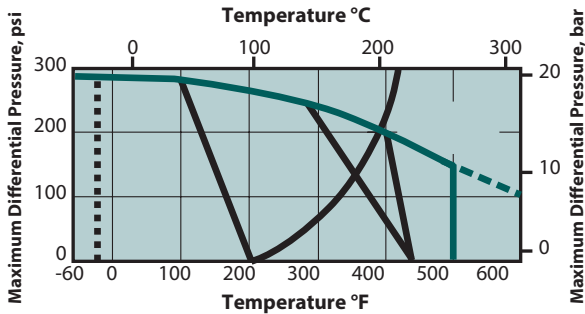

* ASME Class 300 Non-Trunnion is 275 psi (19 bar) max.

10" (DN 250) Standard Bore Non-Trunnion

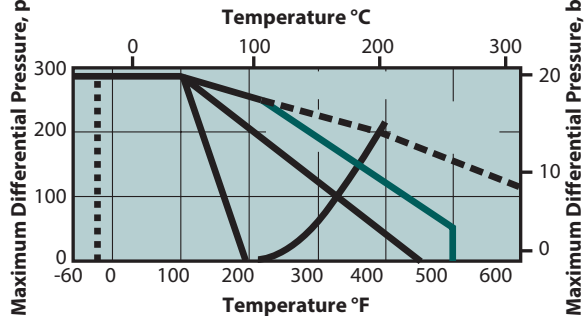

* ASME Class 300 Non-Trunnion is 275 psi (19 bar) max.

**Trunnion Valves
8" – 20" (DN 200 – 500) Standard Bore**

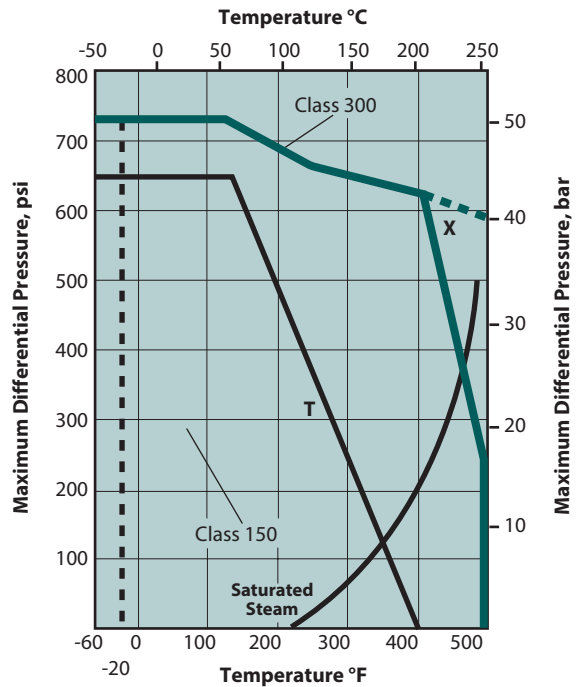

LEGEND:

T = PTFE
L = PEEK

U = UHMW
Z = TFM

B = PFA
X = Xtreme

**'The Ultimate Process Automation Package for VPVL Pneumatic Actuators,
V-Series, ADC-Series and QX-Series Electric Actuators
with 1/2" – 8" (DN 15 – 200) Standard Port Series 7000**

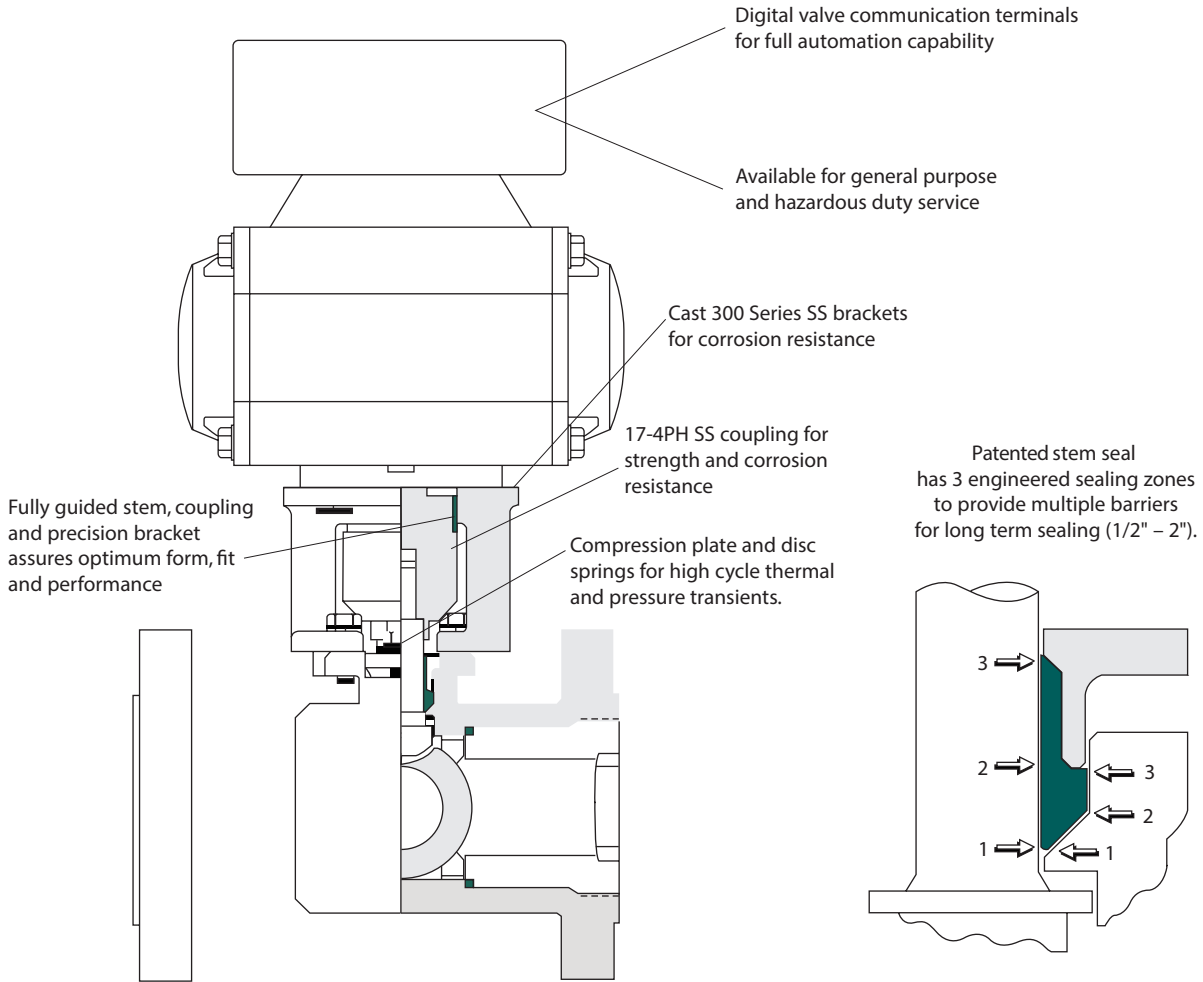

Automation Performance and Value

Valves combined with *Jamesbury* actuators offer a total value and performance package. Available with pneumatic Valv-Powr® VPVL actuators, V-Series, ADC-Series and QX-Series electric actuators and with Stonel® Quartz®

and Hawkeye® digital monitors or VCTs, the packages have a wide range of applications. Visit our website at: www.metso.com/valves

DIMENSIONS

1/2" - 2" (DN15 - 50) Series 7150 ASME Class 150 and Series 7300 & 730S ASME Class 300 (Non-Trunnion)

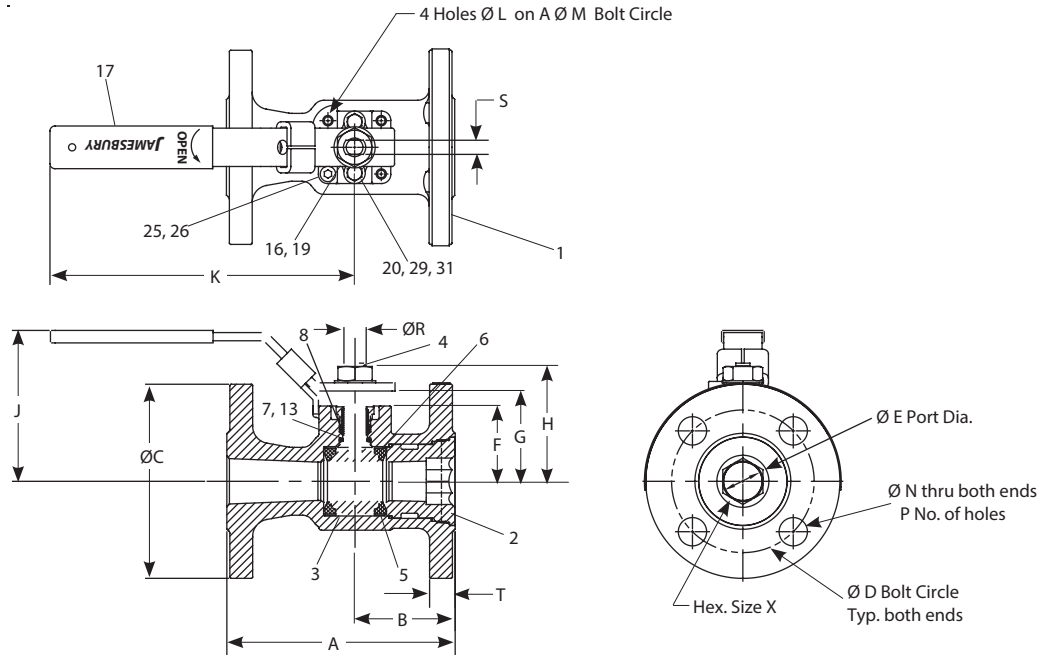

| Valve Size inches | Series 7150 ASME Class 150 Approximate Dimensions - inches | | | | | | | | | | | | | | | | | ISO Bonnet | Approx Weight lb | |
|-------------------|--|------|------|------|------|------|------|------|------|------|----|------|------|---|------|------|------|------------|------------------|------|
| | A | B | C | D | E | F | G | H | J | K | L | M | N | P | R | S | T | | | X |
| 1/2 | 4.25 | 1.94 | 3.50 | 2.38 | 0.50 | 1.06 | 1.33 | 1.63 | 3.38 | 5.00 | M5 | 1.42 | 0.62 | 4 | 0.31 | 0.18 | 0.50 | 0.50 | F03 | 3.5 |
| 3/4 | 4.63 | 2.00 | 3.88 | 2.75 | 0.69 | 1.22 | 1.49 | 1.79 | 3.50 | 5.00 | M5 | 1.42 | 0.62 | 4 | 0.31 | 0.18 | 0.50 | 0.69 | F03 | 4.5 |
| 1 | 5.00 | 2.19 | 4.25 | 3.12 | 0.88 | 1.65 | 2.04 | 2.58 | 3.69 | 6.50 | M5 | 1.65 | 0.62 | 4 | 0.50 | 0.31 | 0.56 | 0.88 | F04 | 7.5 |
| 1-1/2 | 6.50 | 2.65 | 5.00 | 3.88 | 1.25 | 2.08 | 2.59 | 3.30 | 4.27 | 8.00 | M6 | 1.97 | 0.62 | 4 | 0.62 | 0.37 | 0.69 | 1.25 | F05 | 11.5 |
| 2 | 7.00 | 2.64 | 6.00 | 4.75 | 1.50 | 2.26 | 2.78 | 3.49 | 4.46 | 8.00 | M6 | 1.97 | 0.75 | 4 | 0.62 | 0.37 | 0.75 | 1.50 | F05 | 16.0 |

| Valve Size DN | Series 7150 ASME Class 150 Approximate Dimensions - mm | | | | | | | | | | | | | | | | | ISO Bonnet | Approx Weight kg | |
|---------------|--|----|-----|-----|----|----|----|----|-----|-----|----|----|----|---|----|---|----|------------|------------------|-----|
| | A | B | C | D | E | F | G | H | J | K | L | M | N | P | R | S | T | | | X |
| 15 | 108 | 49 | 89 | 60 | 13 | 27 | 34 | 41 | 86 | 127 | M5 | 36 | 16 | 4 | 8 | 5 | 13 | 13 | F03 | 1.6 |
| 20 | 118 | 51 | 99 | 70 | 18 | 31 | 38 | 45 | 89 | 127 | M5 | 36 | 16 | 4 | 8 | 5 | 13 | 18 | F03 | 2.0 |
| 25 | 127 | 56 | 108 | 79 | 22 | 42 | 52 | 66 | 94 | 165 | M5 | 42 | 16 | 4 | 13 | 8 | 14 | 22 | F04 | 3.4 |
| 40 | 165 | 67 | 127 | 99 | 32 | 53 | 66 | 84 | 108 | 203 | M6 | 50 | 16 | 4 | 16 | 9 | 18 | 32 | F05 | 5.2 |
| 50 | 178 | 67 | 152 | 121 | 38 | 57 | 71 | 89 | 113 | 203 | M6 | 50 | 19 | 4 | 16 | 9 | 19 | 38 | F05 | 7.3 |

| Valve Size inches | Series 7300 & 730S ASME Class 300 Approximate Dimensions - inches | | | | | | | | | | | | | | | | | ISO Bonnet | Approx Weight lb | | | |
|-------------------|---|------|------|------|------|------|------|------|------|------|------|----|------|------|---|------|------|------------|------------------|-----|------|------|
| | 7300 | 730S | B | C | D | E | F | G | H | J | K | L | M | N | P | R | S | | T | X | | |
| | A | A | | | | | | | | | | | | | | | | | | | | |
| 1/2 | 5.50 | 4.25 | 1.94 | 3.75 | 2.62 | 0.50 | 1.06 | 1.33 | 1.63 | 3.38 | 5.00 | M5 | 1.42 | 0.62 | 4 | 0.31 | 0.18 | 0.56 | 0.50 | F03 | 5.0 | 6.0 |
| 3/4 | 6.00 | 4.63 | 2.00 | 4.62 | 3.25 | 0.69 | 1.22 | 1.49 | 1.79 | 3.50 | 5.00 | M5 | 1.42 | 0.75 | 4 | 0.31 | 0.18 | 0.62 | 0.69 | F03 | 8.0 | 8.0 |
| 1 | 6.50 | 5.00 | 2.19 | 4.88 | 3.50 | 0.88 | 1.65 | 2.04 | 2.58 | 3.69 | 6.50 | M5 | 1.65 | 0.75 | 4 | 0.50 | 0.31 | 0.69 | 0.88 | F04 | 9.5 | 9.5 |
| 1-1/2 | 7.50 | 6.50 | 2.65 | 6.12 | 4.50 | 1.25 | 2.08 | 2.59 | 3.30 | 4.27 | 8.00 | M6 | 1.97 | 0.88 | 4 | 0.62 | 0.37 | 0.81 | 1.25 | F05 | 17.5 | 16.0 |
| 2 | 8.50 | 7.00 | 2.64 | 6.50 | 5.00 | 1.50 | 2.26 | 2.78 | 3.49 | 4.46 | 8.00 | M6 | 1.97 | 0.75 | 8 | 0.62 | 0.37 | 0.88 | 1.50 | F05 | 21.0 | 22.0 |

| Valve Size DN | Series 7300 & 730S ASME Class 300 Approximate Dimensions - mm | | | | | | | | | | | | | | | | | ISO Bonnet | Approx Weight kg | | | |
|---------------|---|------|----|-----|-----|----|----|----|----|-----|-----|----|----|----|---|----|---|------------|------------------|-----|-----|------|
| | 7300 | 730S | B | C | D | E | F | G | H | J | K | L | M | N | P | R | S | | T | X | | |
| | A | A | | | | | | | | | | | | | | | | | | | | |
| 15 | 140 | 108 | 49 | 95 | 67 | 13 | 27 | 34 | 41 | 86 | 127 | M5 | 36 | 16 | 4 | 8 | 5 | 14 | 13 | F03 | 2.3 | 2.7 |
| 20 | 152 | 118 | 51 | 117 | 83 | 18 | 31 | 38 | 45 | 89 | 127 | M5 | 36 | 19 | 4 | 8 | 5 | 16 | 18 | F03 | 3.6 | 3.6 |
| 25 | 165 | 127 | 56 | 124 | 89 | 22 | 42 | 52 | 66 | 94 | 165 | M5 | 42 | 19 | 4 | 12 | 8 | 18 | 22 | F04 | 4.3 | 4.3 |
| 40 | 191 | 165 | 67 | 155 | 114 | 32 | 53 | 66 | 84 | 108 | 203 | M6 | 50 | 22 | 4 | 16 | 9 | 21 | 32 | F05 | 7.9 | 7.3 |
| 50 | 216 | 178 | 67 | 165 | 127 | 38 | 57 | 71 | 89 | 113 | 203 | M6 | 50 | 19 | 8 | 16 | 9 | 22 | 38 | F05 | 9.5 | 10.0 |

| BILLS OF MATERIALS AND PARTS LIST | | | | | |
|--|---------------------|--|---|------------------------------|---------------------------------|
| Fire-Tite 1/2" – 2" (DN15 – 50) Standard Port Series 7000 Valves | | | | | |
| Part No. | Part Name | Body Material | | | |
| | | Carbon Steel (22) | 316 Stainless Steel (36) | Alloy 20 (35) | Monel (71) |
| 1 | Body | Carbon steel ASTM A216 Type WCB | 316 Stainless steel ASTM A351 Type CF8M | Alloy 20 ASTM A351 Type CN7M | Monel ASTM A494 Type M35-1 |
| 2 | Insert | Carbon steel ASTM A216 Type WCB | 316 Stainless steel ASTM A351 Type CF8M | Alloy 20 ASTM A351 Type CN7M | Monel ASTM A494 Type M35-1 |
| 3 | Ball | 316 Stainless steel, Monel, Hastelloy C | | Alloy 20 | Monel, Hastelloy C as specified |
| 4 | Stem | 316 Stainless steel, Monel, Hastelloy C | | Alloy 20 | Monel, Hastelloy C as specified |
| 5 | Seat | PTFE, Xtreme, PFA | | | |
| 6 | Body Seal | TFM | | | |
| 7 | Secondary Stem Seal | Graphite | | | |
| 8 | Primary Stem Seal | PTFE (w/ PTFE seats), TFM (w/ Xtreme & PFA seats) | | | |
| 13 | Stem Bearing | PTFE, Filled PTFE | | | |
| 16 | Hex Nut | Carbon steel (zinc plated) | 300 Series Stainless steel | | |
| 17 | Handle | Carbon steel (zinc plated) | 300 Series Stainless steel | | |
| 19 | Lock Washer | Carbon steel (zinc plated) | 300 Series Stainless steel | | |
| 20 | Compression Plate | 316 Stainless steel | | | Monel |
| 25 | Socket Cap Screw | 300 Series Stainless steel | | | |
| 26 | Handle Stop Spacer | 300 Series Stainless steel | | | |
| 29 | Hex Cap Screw | 300 Series Stainless steel (Monel if Chlorine or NACE) | | | Monel |
| 31 | Disc Springs | Inconel® | | | |

| BILLS OF MATERIALS AND PARTS LIST | | | | | |
|---|--------------------|--|---|------------------------------|---------------------------------|
| Non Fire-Tite 1/2" – 2" (DN 15 – 50) Standard Port Series 7000 Valves | | | | | |
| Part No. | Part Name | Body Material | | | |
| | | Carbon Steel (22) | 316 Stainless Steel (36) | Alloy 20 (35) | Monel (71) |
| 1 | Body | Carbon steel ASTM A216 Type WCB | 316 Stainless steel ASTM A351 Type CF8M | Alloy 20 ASTM A351 Type CN7M | Monel ASTM A494 Type M35-1 |
| 2 | Insert | Carbon steel ASTM A216 Type WCB | 316 Stainless steel ASTM A351 Type CF8M | Alloy 20 ASTM A351 Type CN7M | Monel ASTM A494 Type M35-1 |
| 3 | Ball | 316 Stainless Steel, Monel, Hastelloy C | | Alloy 20 | Monel, Hastelloy C as specified |
| 4 | Stem | 316 Stainless Steel, Monel, Hastelloy C | | Alloy 20 | Monel, Hastelloy C as specified |
| 5 | Seat | PTFE, Xtreme, PFA, PEEK' & UHMWPE | | | |
| 6 | Body Seal | TFM (w/Xtreme seats), UHMWPE (w/UHMWPE seats), Graphite (w/PEEK seats) | | | |
| 8 | Primary Stem Seal | PTFE (w/ PTFE seats), TFM (w/ Xtreme & PFA seats), UHMWPE (w/ UHMWPE seats), Graphite (w/PEEK seats) | | | |
| 10 | Stem Guide | PEEK (PEEK seated valves) | | | |
| 16 | Hex Nut | Carbon steel (zinc plated) | 300 Series Stainless steel | | |
| 17 | Handle | Carbon steel (zinc plated) | 300 Series Stainless steel | | |
| 19 | Lock Washer | Carbon steel (zinc plated) | 300 Series Stainless steel | | |
| 20 | Compression Plate | 316 Stainless steel | | | Monel |
| 22 | Identification Tag | Stainless steel | | | |
| 23 | Pop Rivet | Stainless steel | | | |
| 24 | Stem Bearing | PTFE (w/ PTFE seats), Filled PTFE (w/ Xtreme & PFA seats), PEEK (w/ PEEK seats), UHMWPE (w/UHMWPE seats) | | | |
| 25 | Socket Cap Screw | 300 Series Stainless steel | | | |
| 26 | Handle Stop Spacer | 300 Series Stainless steel | | | |
| 29 | Hex Cap Screw | 300 Series Stainless steel (Monel if Chlorine or NACE) | | | Monel |
| 31 | Disc Springs | Inconel | | | |

Note 1: 17-4 PH stems required with PEEK seats

DIMENSIONS

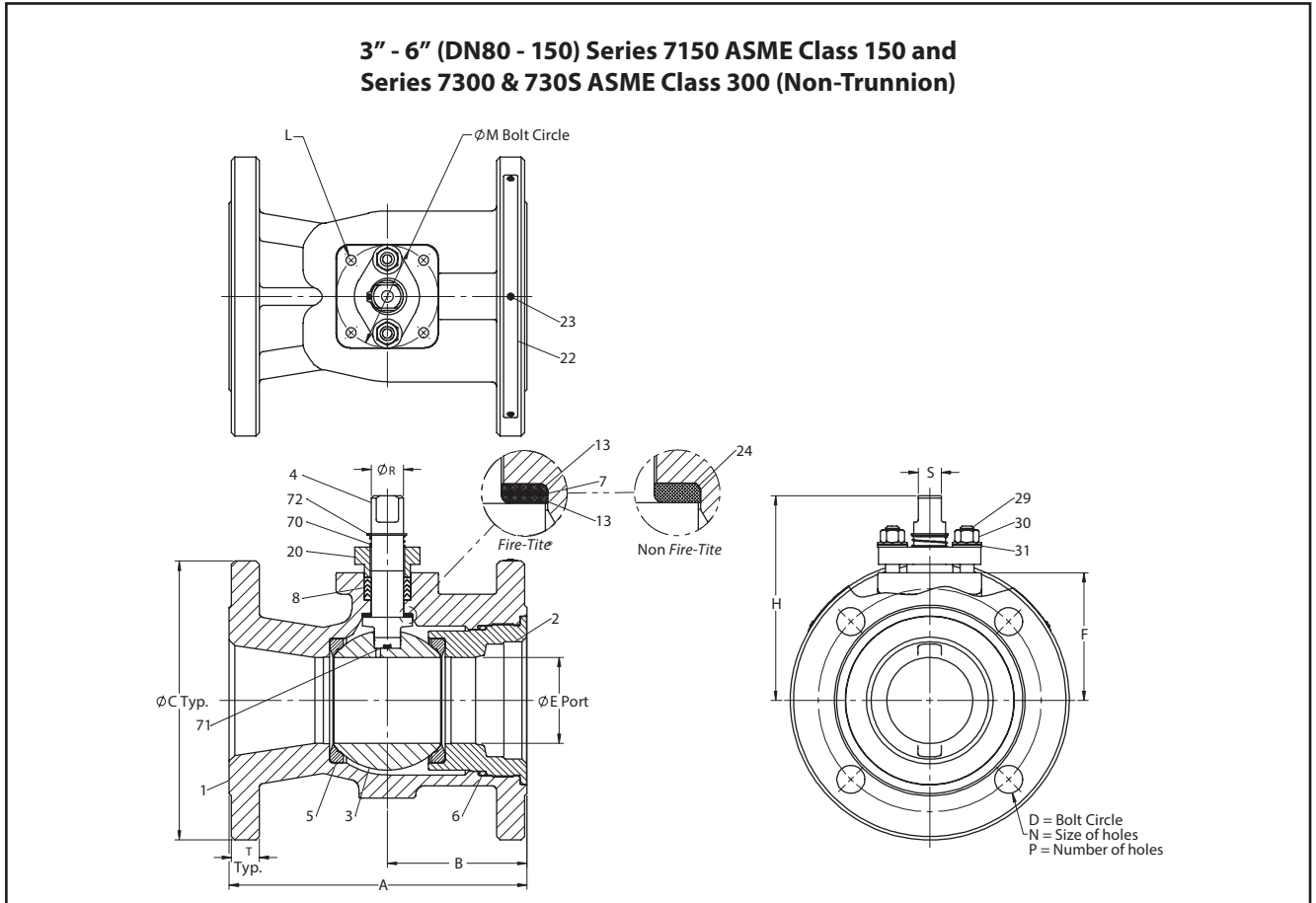

| Valve Size inches | Series 7150 ASME Class 150 Approximate Dimensions - inches | | | | | | | | | | | | | | | ISO Pattern | Weight lb |
|-------------------|--|------|-------|------|------|------|------|-----|------|------|---|------|------|------|-----|-------------|-----------|
| | A | B | C | D | E | F | H | L | M | N | P | R | S | T | | | |
| 3 | 8.00 | 3.75 | 7.50 | 6.00 | 2.31 | 3.43 | 5.51 | M8 | 2.76 | 0.75 | 4 | 0.86 | 0.62 | 0.75 | F07 | 39 | |
| 4 | 9.00 | 4.39 | 9.00 | 7.50 | 3.00 | 3.90 | 6.00 | M8 | 2.76 | 0.75 | 8 | 0.86 | 0.62 | 0.94 | F07 | 63 | |
| 6 | 10.50 | 4.95 | 11.00 | 9.50 | 4.00 | 5.51 | 8.24 | M10 | 4.02 | 0.88 | 8 | 1.11 | 0.81 | 1.00 | F10 | 124 | |

| Valve Size DN | Series 7150 ASME Class 150 Approximate Dimensions - mm | | | | | | | | | | | | | | | ISO Pattern | Weight kg |
|---------------|--|-----|-----|-----|-----|-----|-----|-----|-----|----|---|----|----|----|-----|-------------|-----------|
| | A | B | C | D | E | F | H | L | M | N | P | R | S | T | | | |
| 80 | 203 | 95 | 191 | 152 | 59 | 87 | 140 | M8 | 70 | 19 | 4 | 22 | 16 | 19 | F07 | 18 | |
| 100 | 229 | 111 | 229 | 191 | 76 | 99 | 152 | M8 | 70 | 19 | 8 | 22 | 16 | 24 | F07 | 29 | |
| 150 | 267 | 126 | 279 | 241 | 102 | 140 | 209 | M10 | 102 | 22 | 8 | 28 | 21 | 25 | F10 | 56 | |

| Valve Size inches | Series 7300 & 730S ASME Class 300 Approximate Dimensions - inches | | | | | | | | | | | | | | | ISO Pattern | 7300 Weight lb | 730S Weight lb |
|-------------------|---|--------|------|-------|-------|------|------|------|-----|------|------|----|------|------|------|-------------|----------------|----------------|
| | 7300 A | 730S A | B | C | D | E | F | H | L | M | N | P | R | S | T | | | |
| 3 | 11.12 | 8.00 | 3.75 | 8.25 | 6.62 | 2.31 | 3.44 | 5.51 | M8 | 2.76 | 0.88 | 8 | 0.86 | 0.62 | 1.12 | F07 | 59 | 52 |
| 4 | 12.00 | 9.00 | 4.39 | 10.00 | 7.88 | 3.00 | 4.69 | 7.41 | M10 | 4.11 | 0.88 | 8 | 1.11 | 0.81 | 1.25 | F10 | 96 | 87 |
| 6 | 15.88 | 10.50 | 4.95 | 12.50 | 10.62 | 4.00 | 5.66 | 8.75 | M12 | 4.92 | 0.88 | 12 | 1.61 | 1.12 | 1.44 | F12 | 194 | 160 |

| Valve Size DN | Series 7300 & 730S ASME Class 300 Approximate Dimensions - mm | | | | | | | | | | | | | | | ISO Pattern | 7300 Weight kg | 730S Weight kg |
|---------------|---|--------|-----|-----|-----|-----|-----|-----|-----|-----|----|----|----|----|----|-------------|----------------|----------------|
| | 7300 A | 730S A | B | C | D | E | F | H | L | M | N | P | R | S | T | | | |
| 80 | 282 | 203 | 95 | 210 | 168 | 59 | 87 | 140 | M8 | 70 | 22 | 8 | 22 | 16 | 28 | F07 | 27 | 24 |
| 100 | 305 | 229 | 111 | 254 | 200 | 76 | 119 | 188 | M10 | 104 | 22 | 8 | 28 | 21 | 32 | F10 | 44 | 39 |
| 150 | 403 | 267 | 126 | 318 | 270 | 102 | 144 | 222 | M12 | 125 | 22 | 12 | 41 | 28 | 37 | F12 | 88 | 73 |

| BILLS OF MATERIALS AND PARTS LIST | | | | | |
|---|--------------------------------|---|---|------------------------------|---------------------------------|
| Fire-Tite 3" – 6" (DN80 – 150) Standard Port Series 7000 Valves | | | | | |
| Part No. | Part Name | Body Material | | | |
| | | Carbon Steel (22) | 316 Stainless Steel (36) | Alloy 20 (35) | Monel (71) |
| 1 | Body | Carbon Steel ASTM A216 Type WCB | 316 Stainless Steel ASTM A351 Type CF8M | Alloy 20 ASTM A351 Type CN7M | Monel ASTM A494 M35-1 |
| 2 | Insert | Carbon Steel ASTM A216 Type WCB | 316 Stainless Steel ASTM A351 Type CF8M | Alloy 20 ASTM A351 Type CN7M | Monel ASTM A494 M35-1 |
| 3 | Ball | 316 Stainless Steel, Monel, Hastelloy C | | Alloy 20 | Monel, Hastelloy C as specified |
| 4 | Stem | 316 Stainless Steel, Monel, Hastelloy C | | Alloy 20 | Monel, Hastelloy C as specified |
| 5 | Seat | PTFE, Xtreme, PFA | | | |
| 6 | Body Seal | TFM | | | |
| 7 | Secondary Stem Seal | Graphite | | | |
| 8 | Stem Seal | PTFE (w/ PTFE seats), TFM (w/ Xtreme & PFA seats) | | | |
| 13 | Thrust Bearing | PTFE, Filled PTFE | | | |
| 20 | Compression Plate ¹ | 316 Stainless Steel | | | Monel |
| 22 | Identification Tag | Stainless Steel | | | |
| 23 | Pop Rivet | Stainless Steel | | | |
| 29 | Bonnet Stud | ASTM A193 GR. B8, B8C, B8T or B8M, Monel | | | |
| 30 | Bonnet Stud Nut | ASTM A194 GR. 8B, 8CB, 8MB, 8TB, 8FB, Monel | | | |
| 31 | Disc Springs | Inconel | | | |
| 70 | Top Grounding Spring | Stainless Steel | | | |
| 71 | Bottom Grounding Spring | Inconel | | | |
| 72 | Retaining Ring | Stainless Steel | | | |

| BILLS OF MATERIALS AND PARTS LIST | | | | | |
|--|-------------------------|---|---|------------------------------|---------------------------------|
| Non Fire-Tite 3" – 6" (DN 80 – 150) Standard Port Series 7000 Valves | | | | | |
| Part No. | Part Name | Body Material | | | |
| | | Carbon Steel (22) | 316 Stainless Steel (36) | Alloy 20 (35) | Monel (71) |
| 1 | Body | Carbon Steel ASTM A216 Type WCB | 316 Stainless Steel ASTM A351 Type CF8M | Alloy 20 ASTM A351 Type CN7M | Monel ASTM A494 M35-1 |
| 2 | Insert | Carbon Steel ASTM A216 Type WCB | 316 Stainless Steel ASTM A351 Type CF8M | Alloy 20 ASTM A351 Type CN7M | Monel ASTM A494 M35-1 |
| 3 | Ball | 316 Stainless Steel, Monel, Hastelloy C | | Alloy 20 | Monel, Hastelloy C as specified |
| 4 | Stem | 316 Stainless Steel, Monel, Hastelloy C | | Alloy 20 | Monel, Hastelloy C as specified |
| 5 | Seat | PTFE, Xtreme, PFA, PEEK ² & UHMWPE | | | |
| 6 | Body Seal | TFM (w/ PTFE, Xtreme, PFA seats), UHMWPE (w/ UHMWPE seats), Graphite (w/ PEEK seats) | | | |
| 8 | Stem Seal | PTFE (w/ PTFE seats), TFM (w/ Xtreme & PFA seats), UHMWPE (w/ UHMWPE seats), Graphite (w/ PEEK seats) | | | |
| 13 | Thrust Bearing | PTFE, Filled PTFE | | | |
| 20 | Compression Plate | 316 Stainless Steel | | | Monel |
| 22 | Identification Tag | Stainless Steel | | | |
| 23 | Pop Rivet | Stainless Steel | | | |
| 24 | Thrust Bearing | PTFE (w/ PTFE seats), Filled PTFE (w/ Xtreme & PFA seats), PEEK (w/ PEEK seats), UHMWPE (w/ UHMWPE seats) | | | |
| 29 | Bonnet Stud | ASTM A193 GR. B8, B8C, B8T or B8M, Monel | | | |
| 30 | Bonnet Stud Nut | ASTM A194 GR. 8B, 8CB, 8MB, 8TB, 8FB, Monel | | | |
| 31 | Disc Springs | Inconel | | | |
| 70 | Top Grounding Spring | Stainless Steel | | | |
| 71 | Bottom Grounding Spring | Inconel | | | |
| 72 | Retaining Ring | Stainless Steel | | | |

Note 1: Compression plate and body seal are Monel for valves with Monel or Hastelloy C trim.

Note 2: 17-4PH stems are required with PEEK seats.

DIMENSIONS

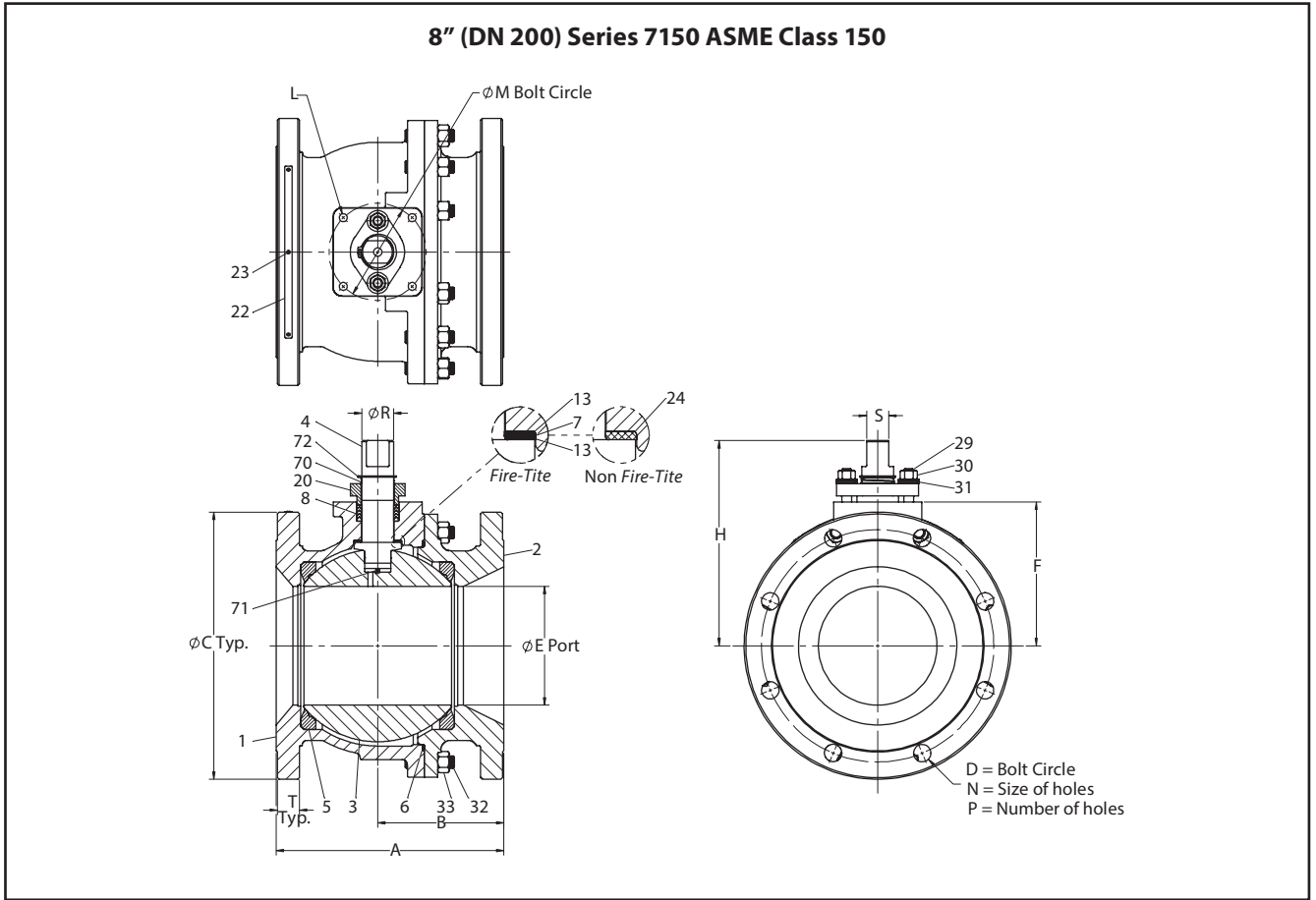

| Valve Size inches | Series 7150 Emission-Pak ASME Class 150 Approximate Dimensions - inches | | | | | | | | | | | | | | ISO Pattern | Weight lb |
|-------------------|---|------|-------|-------|------|-------|-------|-----|------|------|---|------|------|------|-------------|-----------|
| | A | B | C | D | E | F | H | L | M | N | P | R | S | T | | |
| 8 | 11.50 | 6.37 | 13.50 | 11.75 | 6.00 | 11.39 | 14.49 | M12 | 4.92 | 0.88 | 8 | 1.61 | 1.12 | 1.12 | F12 | 282 |

| Valve Size DN | Series 7150 Emission-Pak ASME Class 150 Approximate Dimensions - mm | | | | | | | | | | | | | | ISO Pattern | Weight kg |
|---------------|---|-----|-----|-----|---|-----|-----|-----|-----|----|---|----|----|----|-------------|-----------|
| | A | B | C | D | E | F | H | L | M | N | P | R | S | T | | |
| 200 | 292 | 162 | 343 | 298 | 6 | 289 | 368 | M12 | 125 | 22 | 8 | 41 | 28 | 28 | F12 | 128 |

| BILLS OF MATERIALS AND PARTS LIST | | | | | |
|--|-------------------------|---|---|--------------------------------|---------------------------------|
| Fire-Tite 8" (DN 200) Standard Port Series 7150 Valves | | | | | |
| Part No. | Part Name | Body Material | | | |
| | | Carbon Steel (22) | 316 Stainless Steel (36) | Alloy 20 (35) | Monel (71) |
| 1 | Body | Carbon Steel ASTM A216 Type WCB | 316 Stainless Steel ASTM A351 Type CF8M | Alloy 20 ASTM A351 Type CN7M | Monel ASTM A494 M35-1 |
| 2 | Body Cap | Carbon Steel ASTM A216 Type WCB | 316 Stainless Steel ASTM A351 Type CF8M | Alloy 20 ASTM A351 Type CN7M | Monel ASTM A494 M35-1 |
| 3 | Ball | 316 Stainless Steel, Monel, Hastelloy C | | Alloy 20 | Monel, Hastelloy C as specified |
| 4 | Stem | 316 Stainless Steel, Monel, Hastelloy C | | Alloy 20 | Monel, Hastelloy C as specified |
| 5 | Seat | PTFE, Xtreme, PFA | | | |
| 6 | Body Seal | Spiral Wound Graphite/316 Stainless Steel | | Spiral Wound Graphite/Alloy 20 | Spiral Wound Graphite/Monel |
| 7 | Secondary Stem Seal | Graphite | | | |
| 8 | Stem Seal | PTFE (w/ PTFE seats), TFM (w/ Xtreme & PFA seats) | | | |
| 13 | Thrust Bearing | PTFE, Filled PTFE | | | |
| 20 | Compression Plate | 316 Stainless Steel | | | Monel |
| 22 | Identification Tag | Stainless Steel | | | |
| 23 | Pop Rivet | Stainless Steel | | | |
| 29 | Bonnet Stud | ASTM A193 GR. B8, B8C, B8T or B8M, Monel | | | |
| 30 | Bonnet Stud Nut | ASTM A194 GR. 8B, 8CB, 8MB, 8TB, 8FB, Monel | | | |
| 31 | Disc Springs | Inconel | | | |
| 32 | Body Stud | ASTM A193 GR. B8, B8C, B8T or B8M, Monel | | | |
| 33 | Body Stud Nut | ASTM A194 GR. 8B, 8CB, 8MB, 8TB, 8FB, Monel | | | |
| 70 | Top Grounding Spring | Stainless Steel | | | |
| 71 | Bottom Grounding Spring | Inconel | | | |
| 72 | Retaining Ring | Stainless Steel | | | |

| BILLS OF MATERIALS AND PARTS LIST | | | | | |
|--|-------------------------|---|---|------------------------------|---------------------------------|
| Non Fire-Tite 8" (DN 200) Standard Port Series 7150 Valves | | | | | |
| Part No. | Part Name | Body Material | | | |
| | | Carbon Steel (22) | 316 Stainless Steel (36) | Alloy 20 (35) | Monel (71) |
| 1 | Body | Carbon Steel ASTM A216 Type WCB | 316 Stainless Steel ASTM A351 Type CF8M | Alloy 20 ASTM A351 Type CN7M | Monel ASTM A494 M35-1 |
| 2 | Body Cap | Carbon Steel ASTM A216 Type WCB | 316 Stainless Steel ASTM A351 Type CF8M | Alloy 20 ASTM A351 Type CN7M | Monel ASTM A494 M35-1 |
| 3 | Ball | 316 Stainless Steel, Monel, Hastelloy C | | Alloy 20 | Monel, Hastelloy C as specified |
| 4 | Stem | 316 Stainless Steel, Monel, Hastelloy C | | Alloy 20 | Monel, Hastelloy C as specified |
| 5 | Seat | PTFE, Xtreme, PFA | | | |
| 6 | Body Seal | Spiral Wound PTFE/316 Stainless Steel | Spiral Wound PTFE/Alloy 20 | Spiral Wound PTFE/Monel | |
| 8 | Stem Seal | PTFE (w/ PTFE seats), TFM (w/ Xtreme & PFA seats) | | | |
| 13 | Thrust Bearing | PTFE, Filled PTFE | | | |
| 20 | Compression Plate | 316 Stainless Steel | | | Monel |
| 22 | Identification Tag | Stainless Steel | | | |
| 23 | Pop Rivet | Stainless Steel | | | |
| 29 | Bonnet Stud | ASTM A193 GR. B8, B8C, B8T or B8M, Monel | | | |
| 30 | Bonnet Stud Nut | ASTM A194 GR. 8B, 8CB, 8MB, 8TB, 8FB, Monel | | | |
| 31 | Disc Springs | Inconel | | | |
| 32 | Body Stud | ASTM A193 GR. B8, B8C, B8T or B8M, Monel | | | |
| 33 | Body Stud Nut | ASTM A194 GR. 8B, 8CB, 8MB, 8TB, 8FB, Monel | | | |
| 70 | Top Grounding Spring | Stainless Steel | | | |
| 71 | Bottom Grounding Spring | Inconel | | | |
| 72 | Retaining Ring | Stainless Steel | | | |

DIMENSIONS

**10" (DN 250) Series 7150 ASME Class 150 and
8" & 10" (DN 200 & 250) Series 7300 & 730S ASME Class 300 (Trunnion & Non-Trunnion)**

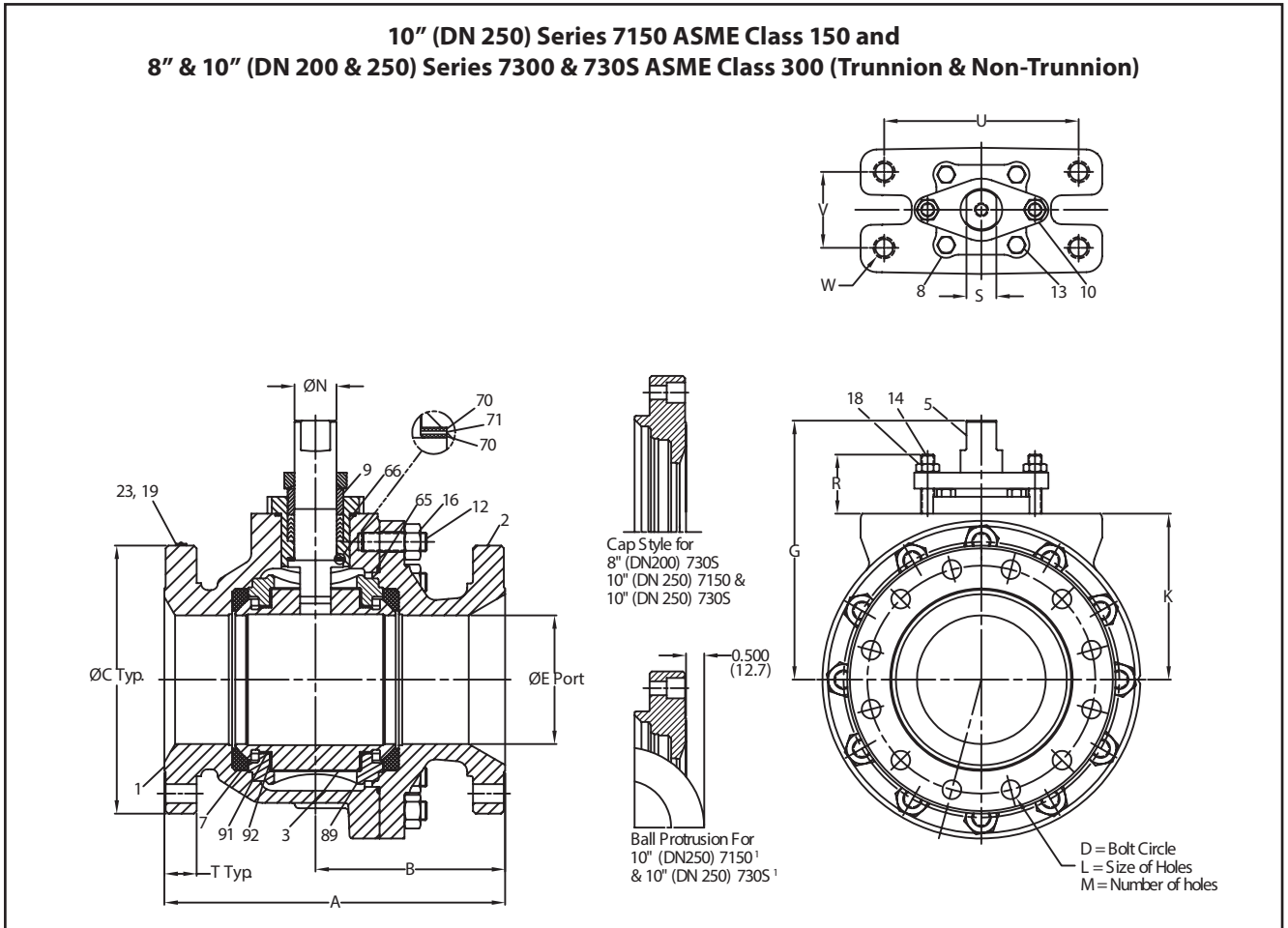

| Valve Size inches | Series 7150 ASME Class 150 Approximate Dimensions – inches | | | | | | | | | | | | | | | | | Weight lb |
|----------------------|--|------|-------|-------|------|-------|-------|------|----|------|------|------|------|------|------|-----|-----|--------------|
| | A | B | C | D | E | G | K | L** | M | N | R | S | T | U | V | W | X | |
| 10 | 13.00 | 5.85 | 16.00 | 14.25 | 8.00 | 15.60 | 10.22 | 1.00 | 12 | 2.54 | 2.88 | 1.82 | 1.19 | 9.06 | 3.54 | 1-8 | N/A | 465 |

| Valve Size DN | Series 7150 ASME Class 150 Approximate Dimensions – mm | | | | | | | | | | | | | | | | | Weight kg |
|------------------|--|-----|-----|-----|-----|-----|-----|-----|----|----|----|----|----|-----|----|-----|-----|--------------|
| | A | B | C | D | E | G | K | L** | M | N | R | S | T | U | V | W* | X | |
| 250 | 330 | 149 | 406 | 362 | 203 | 396 | 260 | 25 | 12 | 65 | 73 | 46 | 30 | 230 | 90 | 1-8 | N/A | 211 |

| Valve Size inches | Series 7300 & 730S ASME Class 300 Approximate Dimensions – inches | | | | | | | | | | | | | | | | | Weight lb | | | |
|----------------------|---|-----------|-----------|-----------|-------|-------|------|-------|-------|------|----|------|------|------|------|------|------|-----------|-----|------|------|
| | 7300 A | 730S A | 7300 B | 730S B | C | D | E | G | K | L** | M | N | R | S | T | U | V | W | X | 7300 | 730S |
| 8 | 16.50 | 11.50 | 10.12 | 5.12 | 15.00 | 13.00 | 6.00 | 12.07 | 7.74 | 1.00 | 12 | 1.95 | 2.76 | 1.39 | 1.68 | 9.06 | 3.54 | 1-8 | N/A | 340 | 327 |
| 10 | 18.00 | 13.00 | 10.85 | 5.85 | 17.50 | 15.25 | 8.00 | 15.60 | 10.22 | 1.13 | 16 | 2.54 | 2.88 | 1.82 | 1.88 | 9.06 | 3.54 | 1-8 | N/A | 695 | 576 |

| Valve Size DN | Series 7300 & 730S ASME Class 300 Approximate Dimensions – mm | | | | | | | | | | | | | | | | | Weight kg | | | |
|------------------|---|-----------|-----------|-----------|-----|-----|-----|-----|-----|-----|----|----|----|----|----|-----|----|-----------|-----|------|------|
| | 7300 A | 730S A | 7300 B | 730S B | C | D | E | G | K | L** | M | N | R | S | T | U | V | W* | X | 7300 | 730S |
| 200 | 419 | 282 | 257 | 130 | 381 | 330 | 152 | 307 | 147 | 25 | 12 | 50 | 70 | 35 | 43 | 230 | 90 | 1-8 | N/A | 154 | 148 |
| 250 | 457 | 330 | 276 | 149 | 445 | 387 | 203 | 396 | 260 | 29 | 16 | 65 | 73 | 46 | 48 | 230 | 90 | 1-8 | N/A | 315 | 261 |

* Screw-thread dimensions are in inches.

** Holes in the body cap are threaded: 8" (DN 200) 730S (7/8-9 x 1.25 deep), 10" (DN 250) 7150 (7/8-9 x 1.13 deep), 10" (DN 250) 730S (1-8 x 1.38 deep)

1 The ball only protrudes from the flange face (in the closed position) on the 10" (DN 250) 7150 and 10" (DN 250) 730S. This is because they have the same F-F dimension and the same ball. Each of these also has the special insert with tapped pipe flange bolt holes.

| BILLS OF MATERIALS AND PARTS LIST | | | |
|--|---------------------------------|---|---------------------------------------|
| 10" (DN 250) Series 7150, 8" & 10" (DN 200 & 250) Series 7300 & 730S | | | |
| Part No. | Part Name | Body Material | |
| | | Carbon Steel (22) All Series | 316 Stainless Steel (36) All Series |
| 1 | Body | Carbon steel ASTM A216 Gr WCB | 316 Stainless steel ASTM A351 Gr CF8M |
| 2 | Body Cap | Carbon steel ASTM A216 Gr WCB | 316 Stainless steel ASTM A351 Gr CF8M |
| 3 | Ball | 316 Stainless steel, Alloy 20, Monel ¹ , Hastelloy C ¹ - as specified | |
| 5 | Stem | 316 Stainless steel, Monel ¹ , Hastelloy C ¹ , 17-4 PH - as specified | |
| 7 | Seat | Xtreme, PTFE - as specified | |
| 8 | Stem Retainer | Carbon steel ASTM A216 Gr WCB | Stainless steel ASTM A351 Gr CF8M |
| 9 | Gland Follower | Carbon Steel, Stainless steel, Monel ¹ | |
| 10 | Compression Plate ¹ | Stainless steel, Monel ¹ | |
| 12 | Body Stud | ASTM A193 Gr B7; Gr B7M; Gr B8, B8C, B8T or B8M | |
| 13 | Stem Retainer Bolt | ASTM A193 Gr B7; Gr B7M; Gr B8, B8C, B8T or B8M | |
| 14 | Stud | ASTM A193 Gr B7; Gr B7M; Gr B8, B8C, B8T or B8M | |
| 16 | Nut | ASTM A194 Gr 2H; Gr 2HM; Gr 8B, 8CB, 8MB, 8TB, 8FB | |
| 18 | Nut | ASTM A194 Gr 2H; Gr 2HM; Gr 8B, 8CB, 8MB, 8TB, 8FB | |
| 19 | Identification Tag | Stainless steel | |
| 23 | Rivet | Stainless steel | |
| 65 | Body Gasket ¹ | Spiral Wound PTFE / 316 Stainless steel ¹ | |
| 66 | Stem Retainer Seal ¹ | Spiral Wound PTFE / 316 Stainless steel ¹ | |
| 69 | Packing | PTFE, molecularly enhanced PTFE (Xtreme-seated valves) | |
| 70 | Stem Bearing | Filled PTFE | |
| 71 | Secondary Stem Seal | Graphite | |
| 89 | Trunnion ² | Carbon Steel | Stainless steel |
| 91 | Bearing Spacer ² | Filled PTFE | |
| 92 | Trunnion Bearing ² | 316 Stainless steel | |

Note 1: Compression plate, body gasket, stem retainer gasket, and gland follower are Monel for valves with Monel or Hastelloy C trim.

Note 2: Parts 89, 91 and 92 are removed from valves without trunnions.

DIMENSIONS

12" – 20" (DN 300 – 500) Series 7150 ASME Class 150 and Series 7300 ASME Class 300 and 12" (DN 300) Series 730S ASME Class 300 (Trunnion)

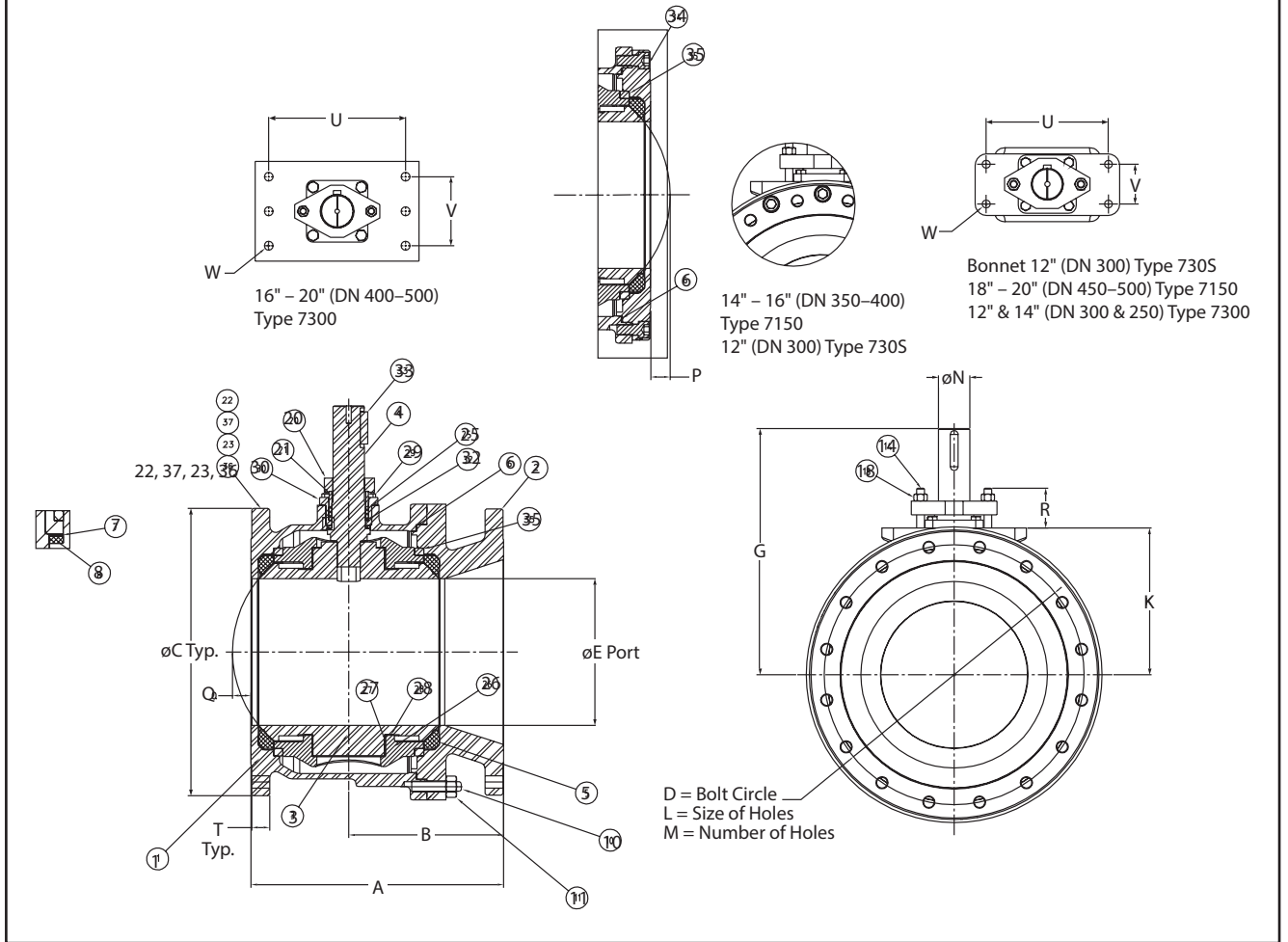

| Valve Size inches | Series 7150 ASME Class 150 Approximate Dimensions - inches | | | | | | | | | | | | | | | Weight lb | | |
|-------------------|--|-------|-------|-------|-------|-------|-------|------|----|------|------|------|------|------|-------|-----------|--------|------|
| | A | B | C | D | E | G | K | L** | M | N | P | Q | R | T | U | | V | W |
| 12 | 14.00 | 7.13 | 19.00 | 17.00 | 10.00 | 17.45 | 10.25 | 1.00 | 12 | 2.13 | 0.84 | 1.00 | 2.5 | 1.19 | 8.00 | 3.25 | 1/2-13 | 620 |
| 14 | 15.00 | 6.75 | 21.00 | 18.75 | 10.00 | 17.50 | 10.25 | 1.13 | 12 | 2.13 | – | 1.18 | 2.5 | 1.31 | 8.00 | 3.25 | 1/2-13 | 850 |
| 16 | 16.00 | 8.00 | 23.50 | 21.25 | 12.00 | 20.19 | 12.00 | 1.13 | 16 | 2.56 | 1.50 | 1.50 | 3.25 | 1.38 | 10.00 | 3.25 | 3/4-10 | 1220 |
| 18 | 34.00 | 22.00 | 25.00 | 22.75 | 13.25 | 24.38 | 13.75 | 1.25 | 16 | 3.00 | – | – | 3.25 | 1.5 | 11.13 | 5.30 | 3/4-10 | 1665 |
| 20 | 36.00 | 22.75 | 27.50 | 25.00 | 15.25 | 25.88 | 15.25 | 1.25 | 20 | 3.00 | – | – | 3.25 | 1.62 | 11.13 | 5.30 | 3/4-10 | 2600 |

| Valve Size DN | Series 7150 ASME Class 150 Approximate Dimensions - mm | | | | | | | | | | | | | | | Weight kg | | |
|---------------|--|-----|-----|-----|-----|-----|-----|-----|----|----|----|----|----|----|-----|-----------|--------|------|
| | A | B | C | D | E | G | K | L** | M | N | P | Q | R | T | U | | V | W* |
| 300 | 356 | 181 | 483 | 432 | 254 | 443 | 260 | 25 | 12 | 54 | 21 | 25 | 64 | 30 | 203 | 83 | 1/2-13 | 281 |
| 350 | 381 | 171 | 533 | 476 | 254 | 445 | 260 | 29* | 12 | 54 | – | 30 | 64 | 33 | 203 | 83 | 1/2-13 | 386 |
| 400 | 406 | 203 | 597 | 540 | 305 | 513 | 305 | 29* | 16 | 65 | 38 | 38 | 83 | 35 | 254 | 83 | 3/4-10 | 553 |
| 450 | 864 | 559 | 635 | 578 | 337 | 619 | 349 | 32 | 16 | 76 | – | – | 83 | 38 | 283 | 135 | 3/4-10 | 755 |
| 500 | 914 | 578 | 699 | 635 | 387 | 657 | 387 | 32 | 20 | 76 | – | – | 83 | 41 | 283 | 135 | 3/4-10 | 1179 |

* Screw-thread dimensions are in inches

** Holes in the body cap are threaded: 12" (DN 300) 730S (1-8 x 1.44 deep), 14" (DN 350) 7150 (1-8 x 1.31 deep), 16" (DN 400) 7150 (1-1/8 x 1.69 deep)

| Valve Size inches | Series 730S & 7300 ASME Class 300 Approximate Dimensions – inches | | | | | | | | | | | | | | | | | | Weight lb | | |
|-------------------|---|---------------------|--------|---------------------|-------|-------|-------|-------|-------|------|----|------|------|------|------|------|-------|------|-----------|------|------|
| | 730S A | 7300 [†] A | 730S B | 7300 [†] B | C | D | E | G | K | L** | M | N | P | Q | R | T | U | V | W | 730S | 7300 |
| 12 | 14.00 | – | 6.88 | – | 20.50 | 17.75 | 10.00 | 21.76 | 11.13 | 1.25 | 16 | 3.00 | 1.05 | – | 3.13 | 1.94 | 11.13 | 5.30 | 1/2-13 | 740 | – |
| 12 | – | 19.75 | – | 12.63 | 20.50 | 17.75 | 10.00 | 21.76 | 11.13 | 1.25 | 16 | 3.00 | – | 0.71 | 3.13 | 1.94 | 11.13 | 5.30 | 1/2-13 | – | 970 |
| 14 | – | 22.50 | – | 13.00 | 23.00 | 20.25 | 10.00 | 21.76 | 11.13 | 1.25 | 20 | 3.00 | – | – | 3.13 | 2.06 | 11.13 | 5.30 | 1/2-13 | – | 1130 |
| 16 | – | 24.00 | – | 14.00 | 25.50 | 22.50 | 12.00 | 23.51 | 12.63 | 1.38 | 20 | 3.50 | – | – | 4 | 2.19 | 13.00 | 7.00 | 3/4-10 | – | 1700 |
| 18 | – | 36.00 | – | 20.81 | 28.00 | 24.75 | 13.25 | 24.94 | 14.00 | 1.38 | 24 | 3.50 | – | – | 4 | 2.31 | 13.00 | 7.00 | 3/4-10 | – | 2000 |
| 20 | – | 28.00 | – | 16.00 | 30.50 | 27.00 | 15.25 | 26.12 | 15.25 | 1.38 | 24 | 3.50 | – | – | 4 | 2.44 | 13.00 | 7.00 | 3/4-10 | – | 3000 |

| Valve Size DN | Series 730S & 7300 ASME Class 300 Approximate Dimensions – mm | | | | | | | | | | | | | | | | | | Weight kg | | |
|---------------|---|---------------------|--------|---------------------|-----|-----|-----|-----|-----|-----|----|----|----|----|-----|----|-----|-----|-----------|------|------|
| | 730S A | 7300 [†] A | 730S B | 7300 [†] B | C | D | E | G | K | L** | M | N | P | Q | R | T | U | V | W* | 730S | 7300 |
| 300 | 356 | – | 175 | – | 521 | 451 | 254 | 553 | 283 | 32 | 16 | 76 | 25 | – | 80 | 49 | 283 | 135 | 1/2-13 | 336 | – |
| 300 | – | 502 | – | 321 | 521 | 451 | 254 | 553 | 283 | 32 | 16 | 76 | – | 18 | 80 | 49 | 283 | 135 | 1/2-13 | – | 417 |
| 350 | – | 572 | – | 330 | 584 | 514 | 254 | 553 | 283 | 32 | 20 | 76 | – | – | 80 | 52 | 283 | 135 | 1/2-13 | – | 513 |
| 400 | – | 610 | – | 356 | 648 | 572 | 305 | 597 | 321 | 35 | 20 | 89 | – | – | 102 | 56 | 330 | 178 | 3/4-10 | – | 771 |
| 450 | – | 914 | – | 529 | 711 | 623 | 337 | 633 | 356 | 35 | 24 | 89 | – | – | 102 | 59 | 330 | 178 | 3/4-10 | – | 907 |
| 500 | – | 711 | – | 406 | 775 | 686 | 387 | 663 | 387 | 35 | 24 | 89 | – | – | 102 | 62 | 330 | 178 | 3/4-10 | – | 1361 |

* Screw-thread dimensions are in inches.

** Holes in the body cap are threaded: 12" (DN 300) 730S (1-8 x 1.44 deep), 14" (DN 350) 7150 (1-8 x 1.31 deep), 16" (DN 400) 7150 (1-1/8-8 x 1.69 deep).

† 18-inch (DN 450) valve is designated 73LO.

| BILLS OF MATERIALS AND PARTS LIST | | | |
|---|--------------------------------|---|--|
| 12" – 20" (DN 300 – 500) Series 7150, 12" – 20" (DN 300 – 500) Series 7300, 18" (DN 450) Series 73LO, and 12" (DN 300) Series 730S (Trunnion) | | | |
| Part No. | Part Name | Body Material | |
| | | Carbon Steel (22) All Series | 316 Stainless Steel (36) All Series |
| 1 | Body | Carbon steel ASTM A216 Type WCB | 316 Stainless steel ASTM A351 Type CF8M |
| 2 | Body Cap | Carbon steel ASTM A216 Type WCB | 316 Stainless steel - ASTM A351 Type CF8M |
| 3 | Ball | 316 Stainless steel, Alloy 20, Monel ¹ , Hastelloy C ¹ - as specified | |
| 4 | Stem | Alloy 20, 316 Stainless steel, 17-4PH Stainless steel, Monel ¹ , Hastelloy C ¹ - as specified | |
| 5 | Seat | PTFE, filled PTFE, - as specified | |
| 6 | Body Seal | Spiral-wound PTFE/316 Stainless steel ¹ | |
| 7 | Secondary Stem Seal | Graphite | |
| 8 | Stem Bearing | Filled PTFE | |
| 10 | Body Stud | ASTM A193 Gr. B7; Gr. B7M; Gr. B8, B8C, B8T or B8M | |
| 11 | Nut | ASTM A194 Gr. 2H, 2HB, or Gr. 2HM; Gr. 8B, 8CB, 8MB, or 8TB | |
| 14 | Bonnet Studs | ASTM A193 Gr. B7; Gr. B7M; Gr. B8, B8C, B8T or B8M | |
| 18 | Bonnet Stud Nut | ASTM A194 Gr. 2H, 2HB, or Gr. 2HM; Gr. 8B, 8CB, 8MB, or 8TB | |
| 20 | Compression Plate | Carbon steel | Stainless steel, Monel ² |
| 21 | Compression Ring | Stainless steel | |
| 22 | Identification Tag | Stainless steel | |
| 23 | Drive Screw | Stainless steel | |
| 25 | Stem Retainer Seal | Graphite | |
| 26 | Trunnion Plate | Carbon steel, Type WCB | 316 Stainless steel ¹ , Type CF8M |
| 27 | Trunnion Bearing | 316 Stainless-steel-backed glass-filled PTFE | |
| 28 | Bearing Spacer | Filled PTFE | |
| 29 | Hex. Hd. Cap Screw | Carbon steel ASTM A193 Gr. B7 or B7M | |
| 30 | Stem Retainer | Carbon steel Type WCB | 316 Stainless steel type CF8M |
| 32 | Upper Stem Seal | PTFE | |
| 33 | Key | Carbon steel | |
| 34 | Sc. Hd. Cap Screw ³ | ASTM A193 Gr. B7; Gr. B7M; Gr. B8, B8C, or B8T | |
| 35 | Trunnion Ring | Carbon steel | Stainless steel |
| 36 | Tag: Trunnion Ball | Stainless steel | |
| 37 | Caution Tag ⁴ | Stainless steel | |

Note 1: When trim is Alloy 20 or Monel, body seal is PTFE Monel, when trim is Hastelloy C, seal is PTFE Hastelloy C.

Note 2: When trim is Alloy 20, Monel, or Hastelloy C, compression plate is Monel.

Note 3: For 14" & 16" (DN 350 & 400) 7150 and 12" (DN 300) 730S only.

Note 4: For 12", 14", & 16" (DN 300, 350, & 400) 7150 and 12" (DN 300) 730S & 7300 only.

VALVE TORQUE DATA

Use these torque charts as a guide for actuator selection. Additional requirements may be imposed by media characteristics, trim, and frequency of valve operation. For clean lubricating fluid service, required torque for PTFE (T), Xtreme (X) and filled PTFE (M) seated valves only may be reduced 20% when the valve is equipped with corrosion resistant trim. For difficult services such as slurries and semi-solids, and for oxygen, increase values by 50%. If in doubt, err on the side of safety by using a larger actuator than would normally be selected.

Torque output values and actuator selection tables for the different types of *Jamesbury* actuators are contained in the bulletins listed below.

| | |
|---------------------------------|-----------------|
| Manual Gear Actuators | A100-1 |
| B-Series Piston Actuators | 6B20 |
| Quadra-Powr® X Spring Diaphragm | |
| Rotary Actuators | A110-4 |
| Valv-Powr Series VPVL | A111-5 |
| VPVL Stainless Steel | A111-4 |
| V-Series Electric Actuators | A200-1 |
| ADC Electric Actuators | A201-1 |
| LC Series Electric Actuators | A202-1 & A203-1 |
| ESR-Series Electric Actuators | A204-1 |
| Q6-Series Electric Actuators | A205-1 |
| QX-Series Electric Actuators | A207-1 |

ASME Class 150 and 300 Valve Torque Data

PTFE (T) Seated Valves

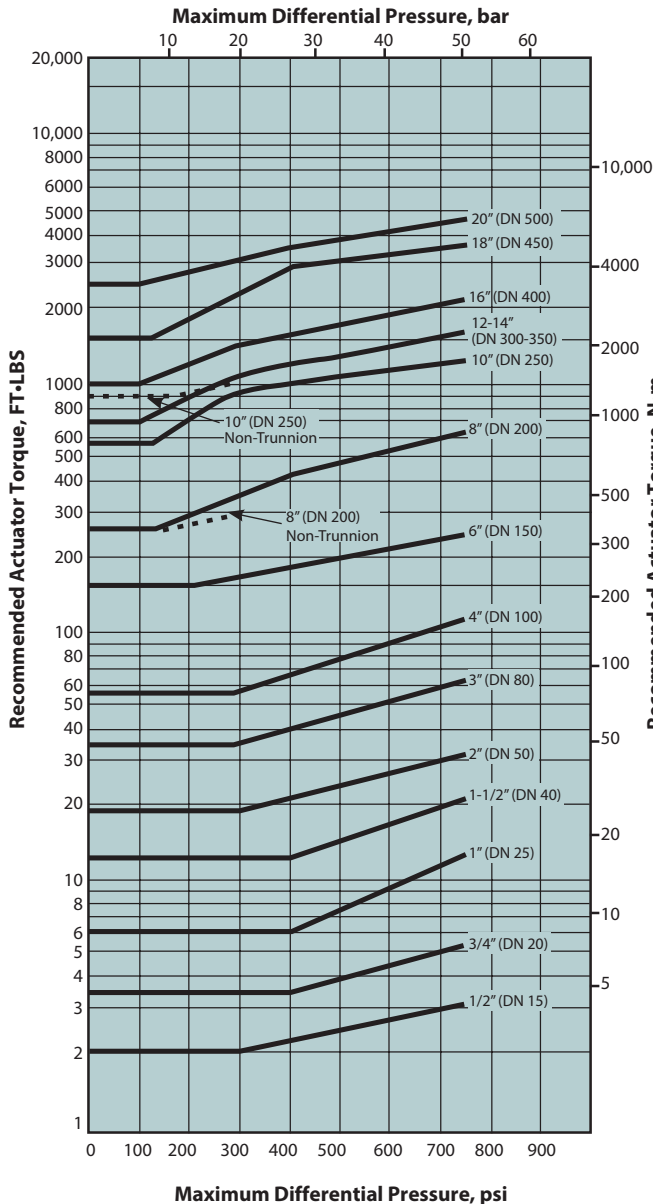

Xtreme (X) and TFM (Z) Seated Valves
1/2" – 10" (DN 15 – 250)

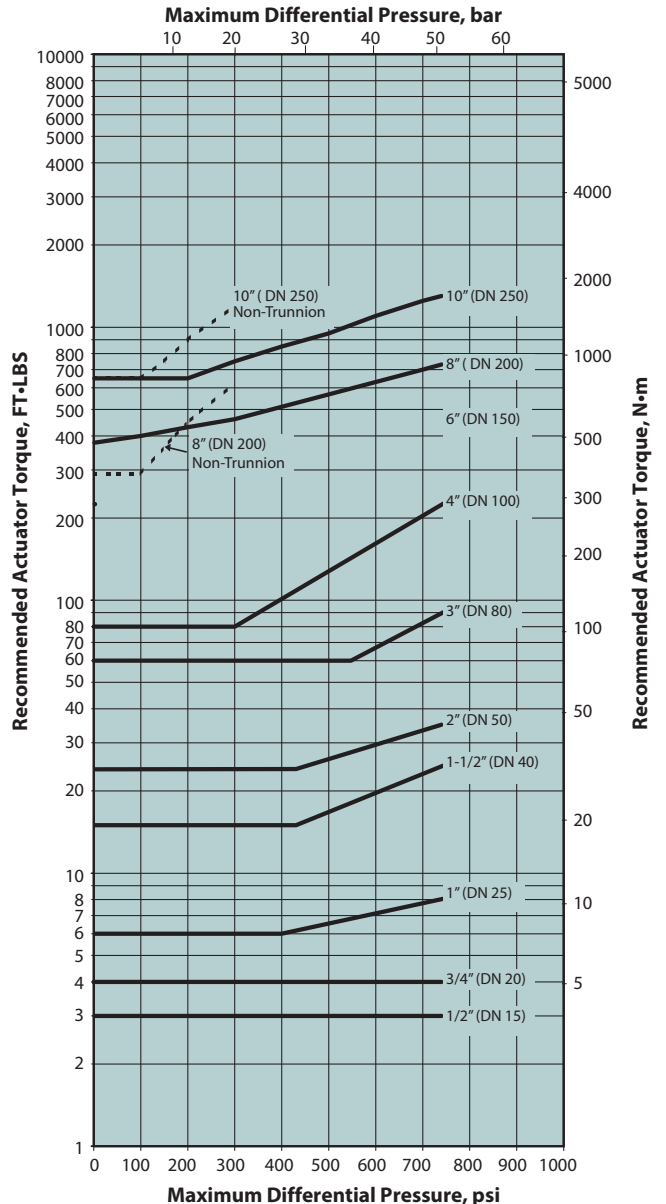

Note: See note on page 16.

VALVE TORQUE DATA

ASME Class 150 and 300 Valves

PEEK (L) Seated Valves 1/2" – 6" (DN 15 – 150)

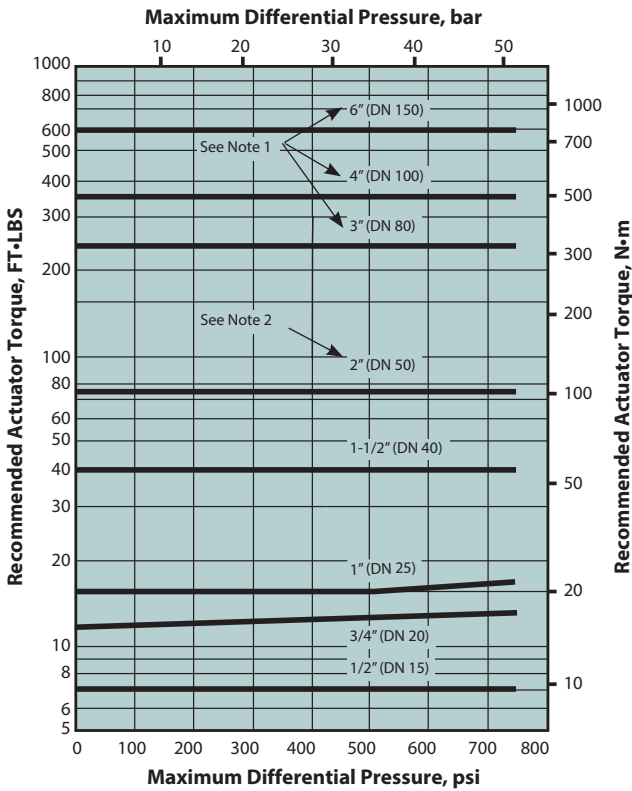

PFA (B) Seated Valves 1/2" – 8" (DN 15 – 200)

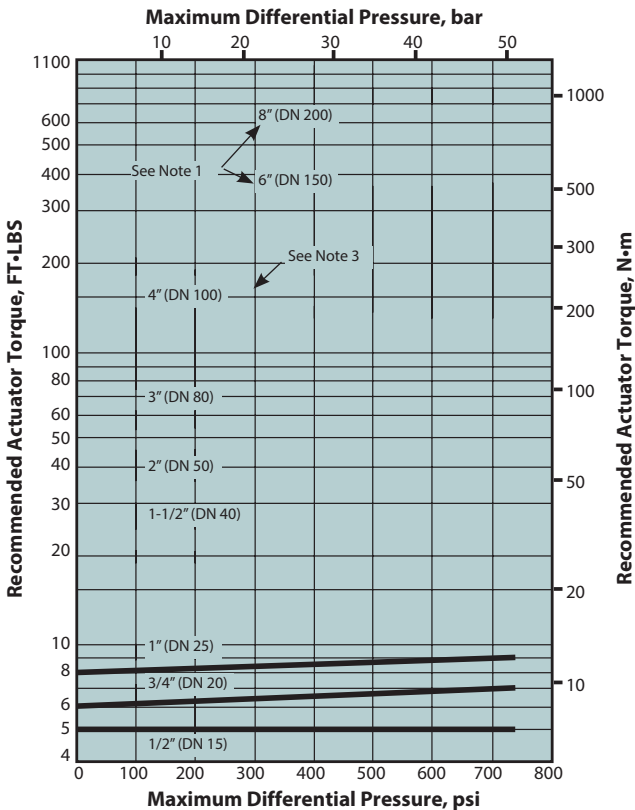

UHMW Polyethylene (U) Seated Valves

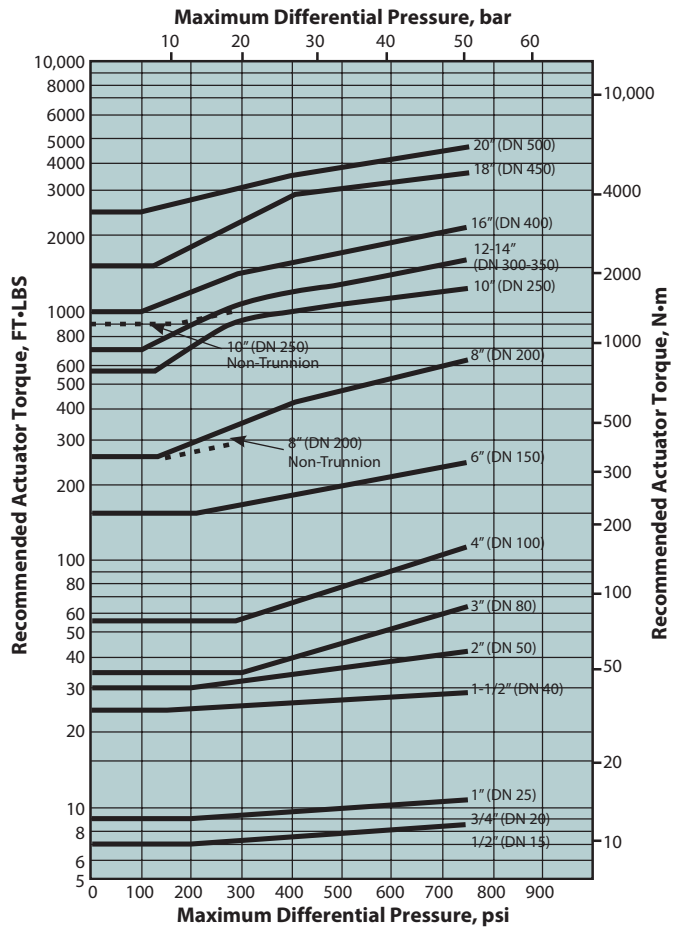

Note 1: Actuator is required.

Note 2: Actuator is required for difficult service.

Note 3: Actuator is required for difficult service and pressure greater than 500 psi.

Note 4: Dashed line indicates Non-Trunnion and is rated to Class 150 only for seats.

EMISSION-PAK SERIES 7000 BALL VALVES

The *Emission-Pak* provides additional protection from emissions and stem seal leakage, and the ability to monitor leakage for critical applications.

The *Emission-Pak* is an extended stem retainer containing two sets of stem seals which is mounted in the valve body. A special TFM and graphite gasket maintains a leak-free joint and assures that a *Fire-Tite* valve retains its fire tested rating.

AVAILABLE CONFIGURATIONS

| Standard Bore Valves | | |
|----------------------|-------------------------|------------|
| Valve | Size Range | ANSI Class |
| 7150, 7180 | 1/2" – 8" (DN 15 – 200) | 150 |
| 730S | 1/2" – 6" (DN 15 – 150) | 300 |
| 7300, 7380 | 1/2" – 6" (DN 15 – 150) | 300 |

FEATURES

- ❑ Two separate live loaded v-ring stem seals
- ❑ One piece stem
- ❑ Two thrust bearings
- ❑ Optional stem seal monitoring port permits detection of primary stem seal wear or leakage
- ❑ ISO 15848 Class AH rated

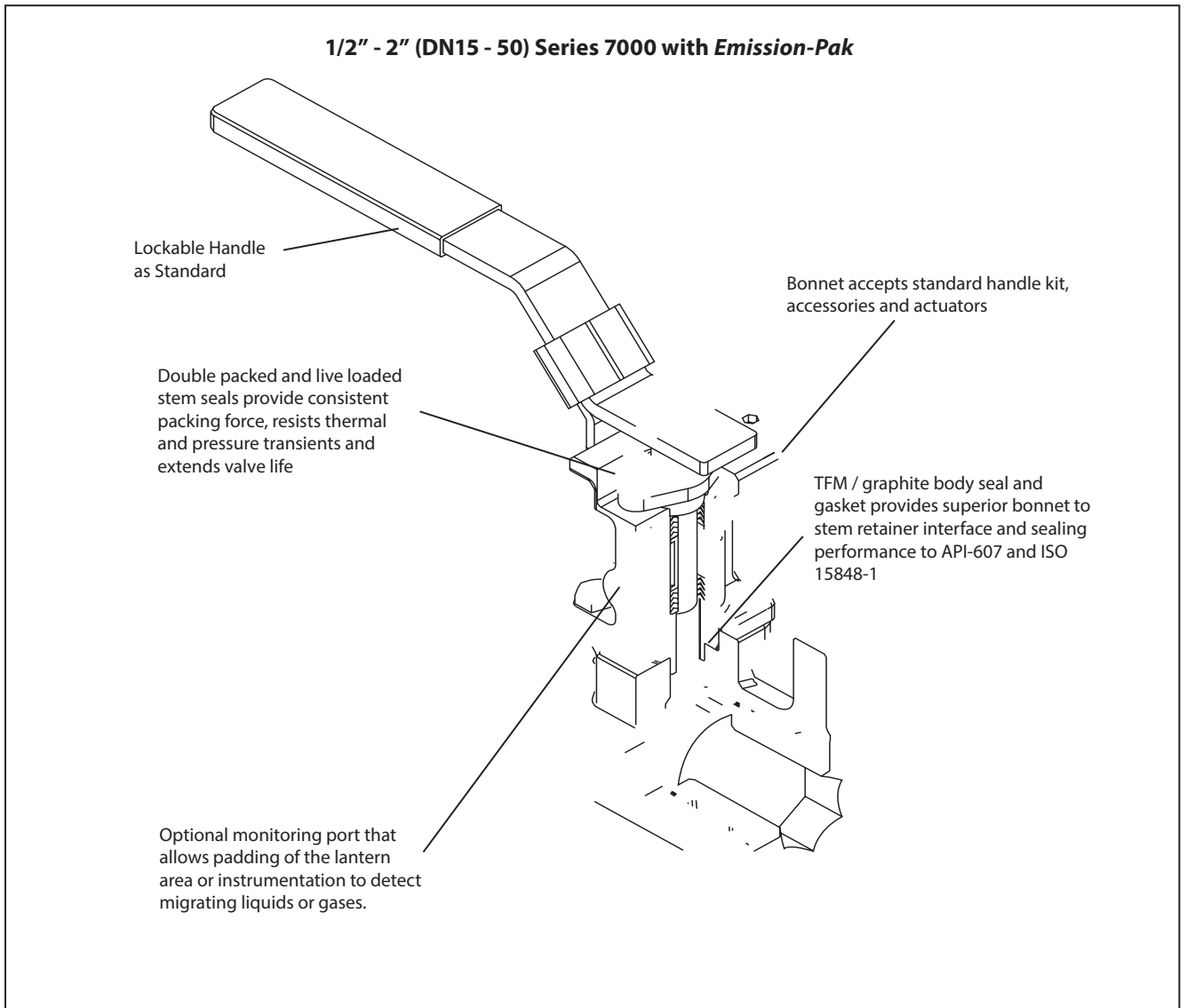

Qualification Test

Emission-Pak 1/2" – 2" (DN 15 – 50) 7000 series are qualified to ISO 15848-1 AH-CC3-SSA1-T200.

DIMENSIONS

1/2" – 2" (DN 15 – 50) Series 7150 ASME Class 150 and Series 7300 & 730S ASME Class 300 with Emission-Pak

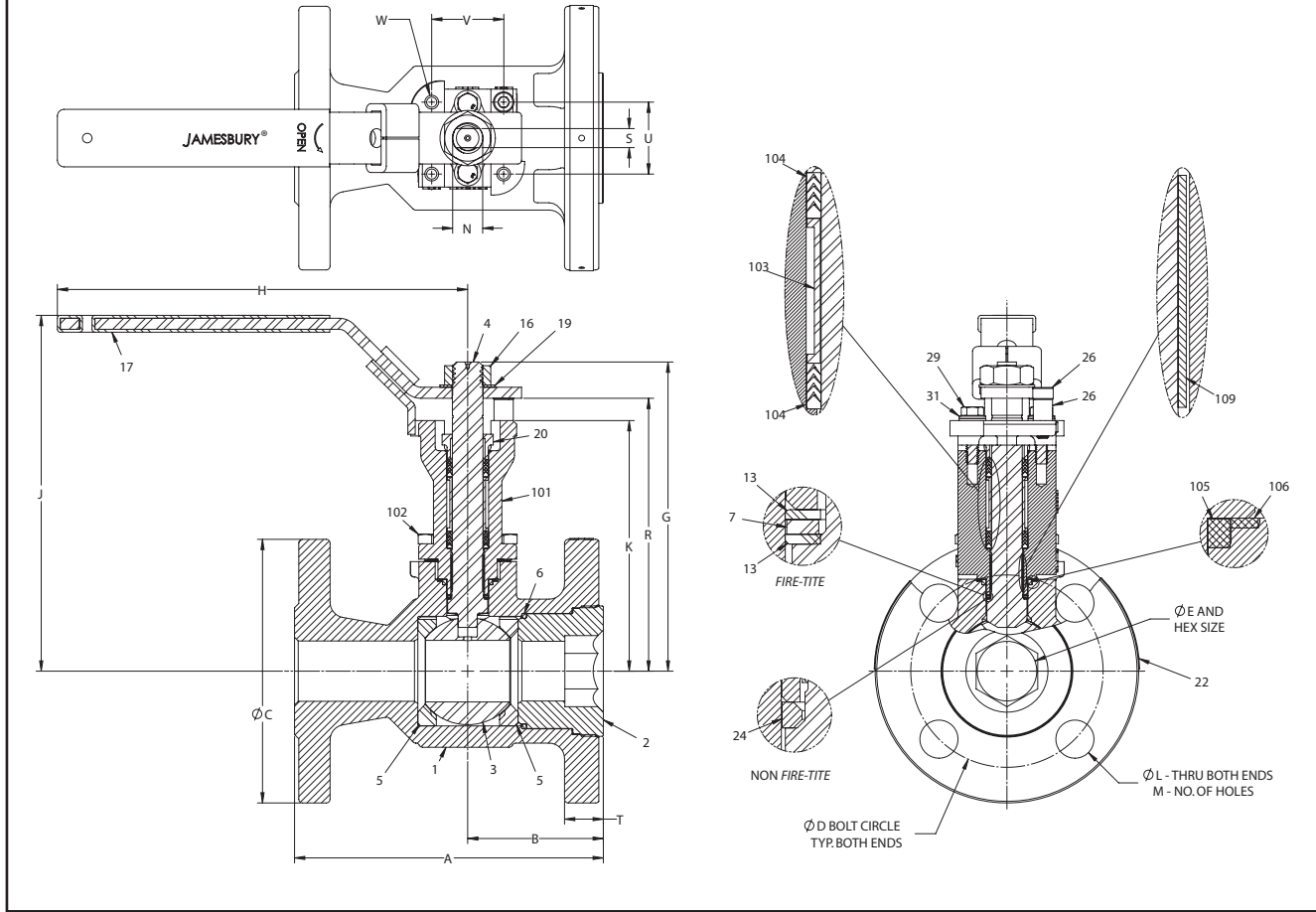

| Valve Size inches | Series 7150 Emission-Pak ASME All Approximate Dimensions - inches | | | | | | | | | | | | | | | | | | ISO Bonnet |
|-------------------|---|------|------|------|------|------|------|------|------|------|---|------|------|------|------|-------|-------|----|------------|
| | A | B | C | D | E | G | H | J | K | L | M | N | R | S | T | U | V | W | |
| 1/2 | 4.25 | 1.94 | 3.50 | 2.38 | 0.50 | 3.61 | 5.00 | 5.17 | 3.08 | 0.62 | 4 | 0.31 | 3.30 | 0.18 | 0.50 | 1.002 | 1.002 | M5 | F03 |
| 3/4 | 4.63 | 2.00 | 3.88 | 2.75 | 0.69 | 3.77 | 5.00 | 5.32 | 3.24 | 0.62 | 4 | 0.31 | 3.46 | 0.18 | 0.50 | 1.002 | 1.002 | M5 | F03 |
| 1 | 5.00 | 2.19 | 4.25 | 3.12 | 0.88 | 4.85 | 6.50 | 5.69 | 3.96 | 0.62 | 4 | 0.50 | 4.30 | 0.31 | 0.56 | 1.168 | 1.168 | M5 | F04 |
| 1-1/2 | 6.50 | 2.65 | 5.00 | 3.88 | 1.25 | 5.81 | 8.00 | 7.34 | 4.63 | 0.62 | 4 | 0.62 | 5.10 | 0.37 | 0.69 | 1.392 | 1.392 | M6 | F05 |
| 2 | 7.00 | 2.64 | 6.00 | 4.75 | 1.50 | 5.99 | 8.00 | 7.52 | 4.81 | 0.75 | 4 | 0.62 | 5.28 | 0.37 | 0.75 | 1.392 | 1.392 | M6 | F05 |

| Valve Size DN | Series 7150 Emission-Pak ASME All Approximate Dimensions - mm | | | | | | | | | | | | | | | | | | ISO Bonnet |
|---------------|---|----|-----|-----|----|-----|-----|-----|-----|----|---|----|-----|---|----|----|----|----|------------|
| | A | B | C | D | E | G | H | J | K | L | M | N | R | S | T | U | V | W | |
| 15 | 108 | 49 | 89 | 60 | 13 | 92 | 127 | 131 | 78 | 16 | 4 | 8 | 84 | 5 | 13 | 25 | 25 | M5 | F03 |
| 20 | 118 | 51 | 99 | 70 | 18 | 96 | 127 | 135 | 82 | 16 | 4 | 8 | 88 | 5 | 13 | 25 | 25 | M5 | F03 |
| 25 | 127 | 56 | 108 | 79 | 22 | 123 | 165 | 145 | 101 | 16 | 4 | 13 | 109 | 8 | 14 | 30 | 30 | M5 | F04 |
| 40 | 165 | 67 | 127 | 99 | 32 | 148 | 203 | 186 | 118 | 16 | 4 | 16 | 130 | 9 | 18 | 35 | 35 | M6 | F05 |
| 50 | 178 | 67 | 152 | 121 | 38 | 152 | 203 | 191 | 122 | 19 | 4 | 16 | 134 | 9 | 19 | 35 | 35 | M6 | F05 |

| Valve Size inches | Series 7300 & 730S Emission-Pak ASME All Approximate Dimensions - inches | | | | | | | | | | | | | | | | | | ISO Bonnet | |
|-------------------|--|--------|------|------|------|------|------|------|------|------|------|---|------|------|------|------|-------|-------|------------|-----|
| | 730S A | 7300 A | B | C | D | E | G | H | J | K | L | M | N | R | S | T | U | V | | W |
| 1/2 | 4.25 | 5.50 | 1.94 | 3.75 | 2.62 | 0.50 | 3.61 | 5.00 | 5.17 | 3.08 | 0.62 | 4 | 0.31 | 3.30 | 0.18 | 0.56 | 1.002 | 1.002 | M5 | F03 |
| 3/4 | 4.63 | 6.00 | 2.00 | 4.62 | 3.25 | 0.69 | 3.77 | 5.00 | 5.32 | 3.24 | 0.75 | 4 | 0.31 | 3.46 | 0.18 | 0.62 | 1.002 | 1.002 | M5 | F03 |
| 1 | 5.00 | 6.50 | 2.19 | 4.88 | 3.50 | 0.88 | 4.85 | 6.50 | 5.69 | 3.96 | 0.75 | 4 | 0.50 | 4.30 | 0.31 | 0.69 | 1.168 | 1.168 | M5 | F04 |
| 1-1/2 | 6.50 | 7.50 | 2.65 | 6.12 | 4.50 | 1.25 | 5.81 | 8.00 | 7.34 | 4.63 | 0.88 | 4 | 0.62 | 5.10 | 0.37 | 0.81 | 1.392 | 1.392 | M6 | F05 |
| 2 | 7.00 | 8.50 | 2.64 | 6.50 | 5.00 | 1.50 | 5.99 | 8.00 | 7.52 | 4.81 | 0.75 | 4 | 0.62 | 5.28 | 0.37 | 0.88 | 1.392 | 1.392 | M6 | F05 |

| Valve Size DN | Series 7300 & 730S Emission-Pak ASME All Approximate Dimensions - mm | | | | | | | | | | | | | | | | | | ISO Bonnet | |
|---------------|--|--------|----|-----|-----|----|-----|-----|-----|-----|----|---|----|-----|---|----|----|----|------------|-----|
| | 730S A | 7300 A | B | C | D | E | G | H | J | K | L | M | N | R | S | T | U | V | | W |
| 15 | 108 | 140 | 49 | 95 | 67 | 13 | 92 | 127 | 131 | 78 | 16 | 4 | 8 | 84 | 5 | 14 | 25 | 25 | M5 | F03 |
| 20 | 118 | 152 | 51 | 117 | 83 | 18 | 96 | 127 | 135 | 82 | 19 | 4 | 8 | 88 | 5 | 16 | 25 | 25 | M5 | F03 |
| 25 | 127 | 165 | 56 | 124 | 89 | 22 | 123 | 165 | 145 | 101 | 19 | 4 | 12 | 109 | 8 | 18 | 30 | 30 | M5 | F04 |
| 40 | 165 | 191 | 67 | 155 | 114 | 32 | 148 | 203 | 186 | 118 | 22 | 4 | 16 | 130 | 9 | 21 | 35 | 35 | M6 | F05 |
| 50 | 178 | 216 | 67 | 165 | 127 | 38 | 152 | 203 | 191 | 122 | 22 | 8 | 16 | 134 | 9 | 22 | 35 | 35 | M6 | F05 |

| BILLS OF MATERIALS AND PARTS LIST | | | | | |
|--|--------------------------|--|---|------------------------------|---------------------------------|
| Fire- Tite 1/2" – 2" (DN 15 – 50) Standard Port Series 7000 Valves with Emission-Pak | | | | | |
| Part No. | Part Name | Body Material | | | |
| | | Carbon Steel (22) | 316 Stainless Steel (36) | Alloy 20 (35) | Monel (71) |
| 1 | Body | Carbon Steel ASTM A216 Type WCB | 316 Stainless Steel ASTM A351 Type CF8M | Alloy 20 ASTM A351 Type CN7M | Monel ASTM A494 M35-1 |
| 2 | Insert | Carbon Steel ASTM A216 Type WCB | 316 Stainless Steel ASTM A351 Type CF8M | Alloy 20 ASTM A351 Type CN7M | Monel ASTM A494 M35-1 |
| 3 | Ball | 316 Stainless Steel, Monel, Hastelloy C | | Alloy 20 | Monel, Hastelloy C as specified |
| 4 | Stem | 316 Stainless Steel, Monel, Hastelloy C | | Alloy 20 | Monel, Hastelloy C as specified |
| 5 | Seat | PTFE, Xtreme, PFA | | | |
| 6 | Body Seal | TFM | | | |
| 7 | Secondary Stem Seal | Graphite | | | |
| 13 | Stem Bearing | PTFE, Filled PTFE | | | |
| 16 | Hex Nut | Carbon Steel (zinc plated) | | | |
| 17 | Handle | Carbon Steel (zinc plated) | 300 Series Stainless Steel | | |
| 19 | Lock Washer | Carbon Steel (zinc plated) | 300 Series Stainless Steel | | |
| 22 | Identification Tag | Stainless Steel | | | |
| 23 | Pop Rivet | Stainless Steel | | | |
| 20 | Compression Plate | 316 Stainless Steel | 300 Series Stainless Steel | | |
| 25 | Socket Cap Screw | 300 Stainless Steel | | | Monel |
| 26 | Handle Stop Screw | 300 Stainless Steel | | | |
| 29 | Hex Cap Screw | 300 Stainless Steel (Monel if Chlorine or NACE) | | | Monel |
| 31 | Disc Springs | Inconel | | | |
| 101 | Emission-Pak Housing | Carbon Steel ASTM A216 Type WCB | 316 Stainless Steel ASTM A351 Type CF8M | Alloy 20 ASTM A351 Type CN7M | Monel ASTM A494 M35-1 |
| 102 | Hex Head Cap Screw | ASTM A193 GR. B7, ASTM A193 GR. B8, B8C, B8T or B8M, Monel | | | |
| 103 | Lantern Ring | 316 Stainless Steel, Monel, Alloy 20 | | | |
| 104 | Double Stem Seals | TFM | | | |
| 105 | Emission-Pak Body Seal | TFM | | | |
| 106 | Emission-Pak Body Gasket | Graphite | | | |
| 107 | Pipe Plug | Plastic | | | |
| 109 | Bearing Strip | PTFE | | | |
| 112 | Warning Tag | Polyethylene | | | |

| BILLS OF MATERIALS AND PARTS LIST | | | | | |
|---|---------------------------------|--|---|------------------------------|---------------------------------|
| Non Fire- Tite 1/2" – 2" (DN 15 – 50) Standard Port Series 7000 Valves with <i>Emission- Pak</i> | | | | | |
| Part No. | Part Name | Body Material | | | |
| | | Carbon Steel (22) | 316 Stainless Steel (36) | Alloy 20 (35) | Monel (71) |
| 1 | Body | Carbon Steel ASTM A216 Type WCB | 316 Stainless Steel ASTM A351 Type CF8M | Alloy 20 ASTM A351 Type CN7M | Monel ASTM A494 M35-1 |
| 2 | Insert | Carbon Steel ASTM A216 Type WCB | 316 Stainless Steel ASTM A351 Type CF8M | Alloy 20 ASTM A351 Type CN7M | Monel ASTM A494 M35-1 |
| 3 | Ball | 316 Stainless Steel, Monel, Hastelloy C | | Alloy 20 | Monel, Hastelloy C as specified |
| 4 | Stem | 316 Stainless Steel, Monel, Hastelloy C | | Alloy 20 | Monel, Hastelloy C as specified |
| 5 | Seat | PTFE, <i>Xtreme</i> , PFA, PEEK' & UHMWPE | | | |
| 6 | Body Seal | TFM (w/ PTFE, <i>Xtreme</i> , PFA seats), UHMWPE (w/ UHMWPE seats), Graphite (w/ PEEK seats) | | | |
| 8 | Primary Stem Seal | PTFE (w/ PTFE seats), TFM (w/ <i>Xtreme</i> & PFA seats), UHMWPE (w/ UHMWPE seats), Graphite (w/ PEEK seats) | | | |
| 10 | Stem Guide | PEEK (PEEK seated valves) | | | |
| 16 | Hex Nut | Carbon Steel (zinc plated) | 300 Series Stainless Steel | | |
| 17 | Handle | Carbon Steel (zinc plated) | 300 Series Stainless Steel | | |
| 19 | Lock Washer | Carbon Steel (zinc plated) | 300 Series Stainless Steel | | |
| 20 | Compression Plate | 316 Stainless Steel | | | Monel |
| 22 | Identification Tag | Stainless Steel | | | |
| 23 | Pop Rivet | Stainless Steel | | | |
| 24 | Stem Bearing | PTFE (w/ PTFE seats), Filled PTFE (w/ <i>Xtreme</i> & PFA seats), PEEK (w/ PEEK seats), UHMWPE (w/ UHMWPE seats) | | | |
| 25 | Socket Cap Screw | 300 Stainless Steel | | | |
| 26 | Handle Stop Screw | 300 Stainless Steel | | | |
| 29 | Hex Cap Screw | 300 Stainless Steel (Monel if Chlorine or NACE) | | | Monel |
| 31 | Disc Springs | Inconel | | | |
| 101 | <i>Emission-Pak</i> Housing | Carbon Steel ASTM A216 Type WCB | 316 Stainless Steel ASTM A351 Type CF8M | Alloy 20 ASTM A351 Type CN7M | Monel ASTM A494 M35-1 |
| 102 | Hex Head Cap Screw | ASTM A193 GR. B7, ASTM A193 GR. B8, B8C, B8T or B8M, Monel | | | |
| 103 | Lantern Ring | 316 Stainless Steel, Monel, Alloy 20 | | | |
| 104 | Double Stem Seals | TFM (w/ <i>Xtreme</i> , PTFE & PFA seats), UHMWPE (w/ UHMWPE seats), Graphite (w/ PEEK seats) | | | |
| 105 | <i>Emission-Pak</i> Body Seal | TFM, UHMWPE (w/ UHMWPE seats) | | | |
| 106 | <i>Emission-Pak</i> Body Gasket | Graphite | | | |
| 107 | Pipe Plug | Plastic | | | |
| 109 | Bearing Strip | PTFE | | | |
| 112 | Warning Tag | Polyethylene | | | |

Note 1: 17-4 PH stems required with PEEK seats

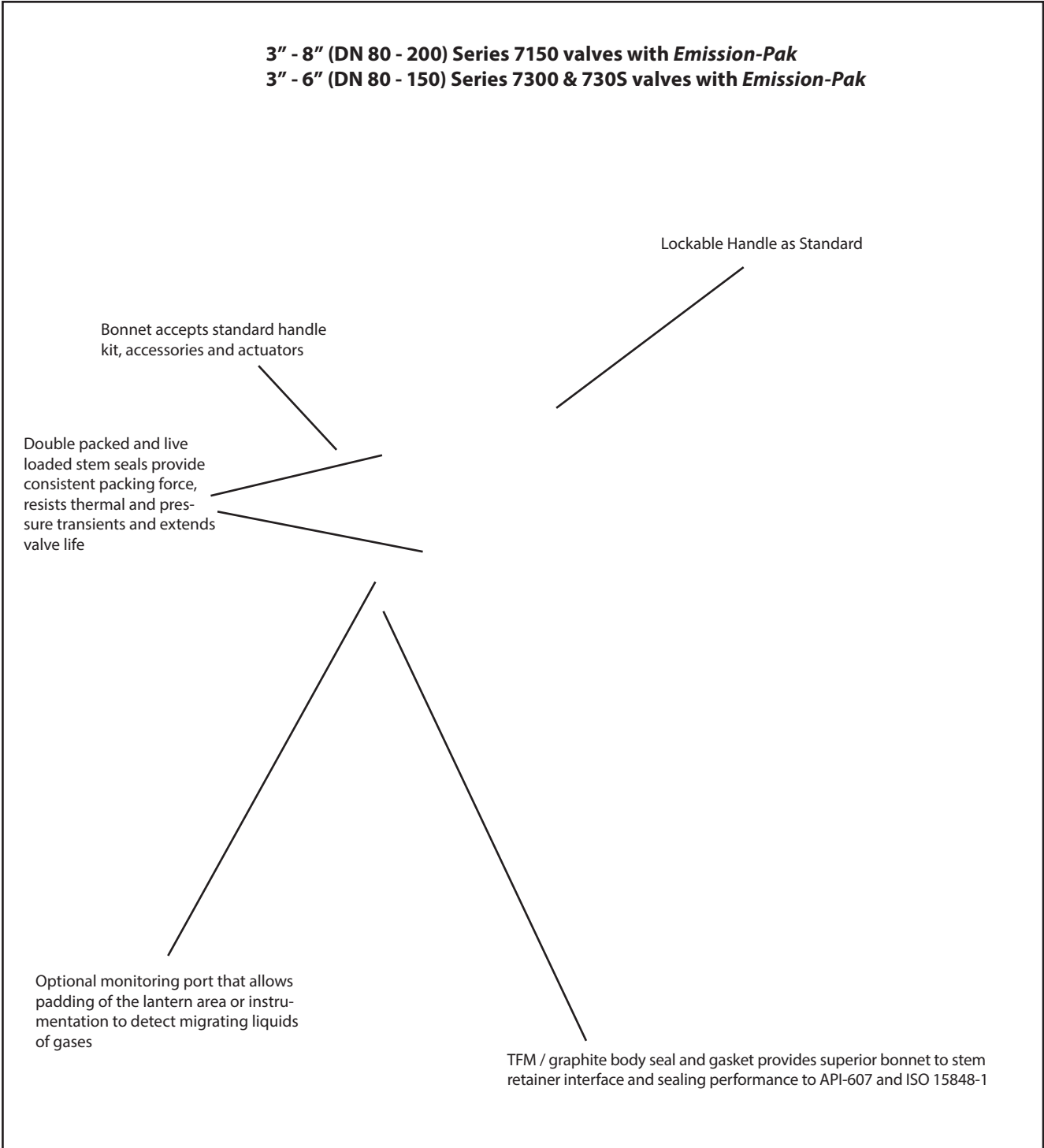

Qualification Test

3" – 8" (DN 80 – 200) 7150, 3" - 6" (DN 80 - 150) 7300 and 730S, series with *Emission-Pak* are qualified to ISO 15848-1 AH CO3-SSA3 T(200°C).

DIMENSIONS

3" – 6" (DN 80 – 150) Series 7150, 730S and 7300 with Emission-Pak

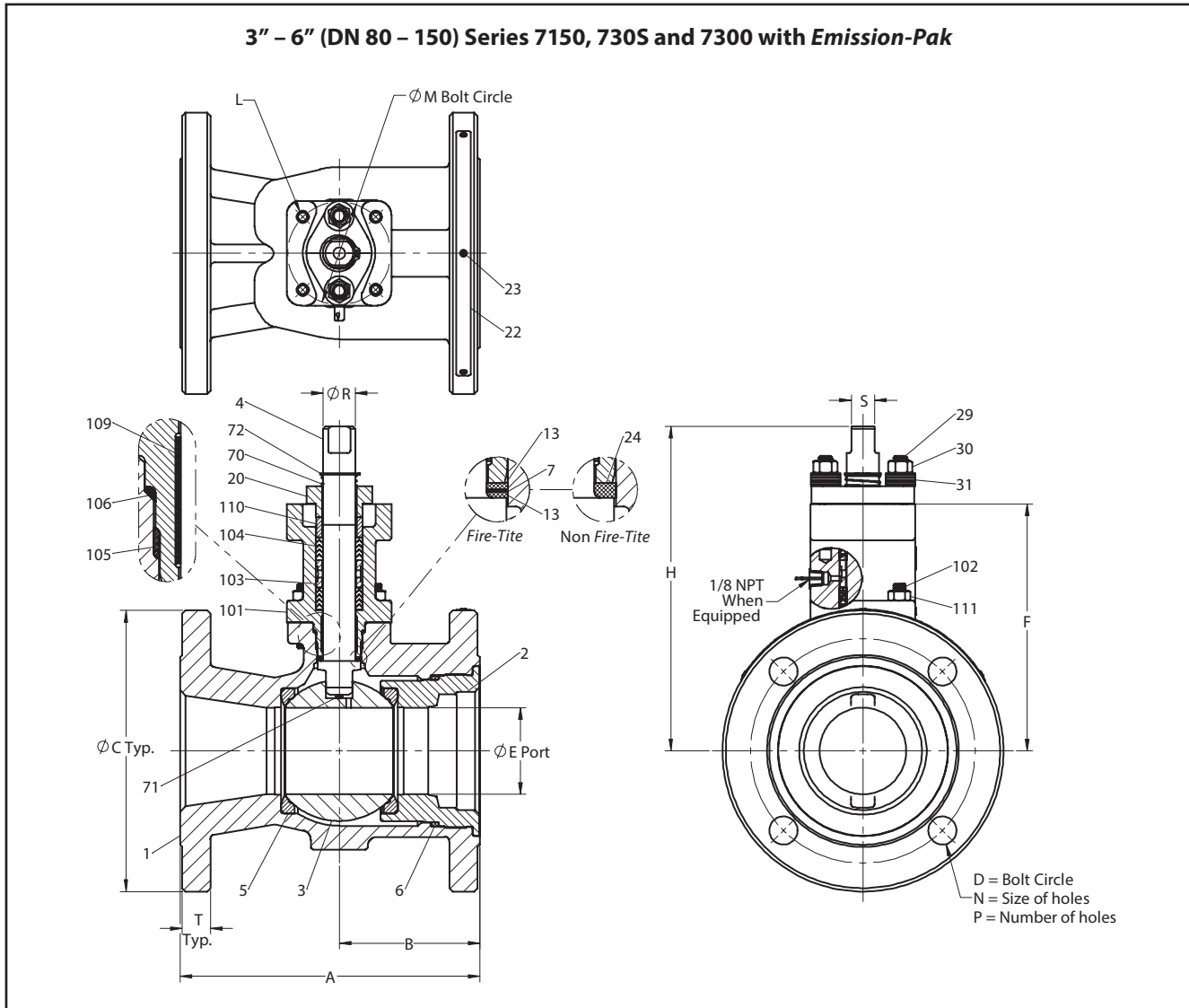

| Valve Size inches | Series 7150 Emission-Pak ASME Class 150 Approximate Dimensions - inches | | | | | | | | | | | | | | ISO Pattern | Weight lb |
|-------------------|---|------|-------|------|------|------|-------|-----|------|------|---|------|------|------|-------------|-----------|
| | A | B | C | D | E | F | H | L | M | N | P | R | S | T | | |
| 3 | 8.00 | 3.75 | 7.50 | 6.00 | 2.31 | 6.59 | 8.66 | M8 | 2.76 | 0.75 | 4 | 0.86 | 0.62 | 0.75 | F07 | 49 |
| 4 | 9.00 | 4.39 | 9.00 | 7.50 | 3.00 | 7.05 | 9.12 | M8 | 2.76 | 0.75 | 8 | 0.86 | 0.62 | 0.94 | F07 | 73 |
| 6 | 10.50 | 4.95 | 11.00 | 9.50 | 4.00 | 9.45 | 12.18 | M10 | 4.02 | 0.88 | 8 | 1.11 | 0.81 | 1.00 | F10 | 140 |

| Valve Size DN | Series 7150 Emission-Pak ASME Class 150 Approximate Dimensions - mm | | | | | | | | | | | | | | ISO Pattern | Weight kg |
|---------------|---|-----|-----|-----|-----|-----|-----|-----|-----|----|---|----|----|----|-------------|-----------|
| | A | B | C | D | E | F | H | L | M | N | P | R | S | T | | |
| 80 | 203 | 95 | 191 | 152 | 59 | 167 | 220 | M8 | 70 | 19 | 4 | 22 | 16 | 19 | F07 | 22 |
| 100 | 229 | 111 | 229 | 191 | 76 | 179 | 232 | M8 | 70 | 19 | 8 | 22 | 16 | 24 | F07 | 33 |
| 150 | 267 | 126 | 279 | 241 | 102 | 240 | 309 | M10 | 102 | 22 | 8 | 28 | 21 | 25 | F10 | 64 |

| Valve Size inches | Series 7300 & 730S Emission-Pak ASME Class 300 Approximate Dimensions - inches | | | | | | | | | | | | | | ISO Pattern | 7300 Weight lb | 730S Weight lb | |
|-------------------|--|--------|------|-------|-------|------|------|-------|-----|------|------|----|------|------|-------------|----------------|----------------|-----|
| | 7300 A | 730S A | B | C | D | E | F | H | L | M | N | P | R | S | | | | T |
| 3 | 11.12 | 8.00 | 3.75 | 8.25 | 6.62 | 2.31 | 6.59 | 8.66 | M8 | 2.76 | 0.88 | 8 | 0.86 | 0.62 | 1.12 | F07 | 69 | 62 |
| 4 | 12.00 | 9.00 | 4.39 | 10.00 | 7.88 | 3.00 | 8.63 | 11.35 | M10 | 4.11 | 0.88 | 8 | 1.11 | 0.81 | 1.25 | F10 | 112 | 103 |
| 6 | 15.88 | 10.50 | 4.95 | 12.50 | 10.62 | 4.00 | 9.77 | 12.87 | M12 | 4.92 | 0.88 | 12 | 1.61 | 1.12 | 1.44 | F12 | 226 | 192 |

| Valve Size DN | Series 7300 & 730S Emission-Pak ASME Class 300 Approximate Dimensions - mm | | | | | | | | | | | | | | ISO Pattern | 7300 Weight kg | 730S Weight kg | |
|---------------|--|--------|-----|-----|-----|-----|-----|-----|-----|-----|----|----|----|----|-------------|----------------|----------------|----|
| | 7300 A | 730S A | B | C | D | E | F | H | L | M | N | P | R | S | | | | T |
| 80 | 282 | 203 | 95 | 210 | 168 | 59 | 167 | 220 | M8 | 70 | 22 | 8 | 22 | 16 | 28 | F07 | 31 | 28 |
| 100 | 305 | 229 | 111 | 254 | 200 | 76 | 219 | 288 | M10 | 104 | 22 | 8 | 28 | 21 | 32 | F10 | 51 | 47 |
| 150 | 403 | 267 | 126 | 318 | 270 | 102 | 248 | 327 | M12 | 125 | 22 | 12 | 41 | 28 | 37 | F12 | 103 | 87 |

| BILLS OF MATERIALS AND PARTS LIST | | | | | |
|--|----------------------------|---|---|------------------------------|---------------------------------|
| Fire-Tite 3" – 6" (DN 80 – 150) Standard Port Series 7000 Valves with Emission-Pak | | | | | |
| Part No. | Part Name | Body Material | | | |
| | | Carbon Steel (22) | 316 Stainless Steel (36) | Alloy 20 (35) | Monel (71) |
| 1 | Body | Carbon Steel ASTM A216 Type WCB | 316 Stainless Steel ASTM A351 Type CF8M | Alloy 20 ASTM A351 Type CN7M | Monel ASTM A494 M35-1 |
| 2 | Insert | Carbon Steel ASTM A216 Type WCB | 316 Stainless Steel ASTM A351 Type CF8M | Alloy 20 ASTM A351 Type CN7M | Monel ASTM A494 M35-1 |
| 3 | Ball | 316 Stainless Steel, Monel, Hastelloy C | | Alloy 20 | Monel, Hastelloy C as specified |
| 4 | Stem | 316 Stainless Steel, Monel, Hastelloy C | | Alloy 20 | Monel, Hastelloy C as specified |
| 5 | Seat | PTFE, Xtreme, PFA | | | |
| 6 | Body Seal | TFM | | | |
| 7 | Secondary Stem Seal | Graphite | | | |
| 13 | Thrust Bearing | PTFE, Filled PTFE | | | |
| 20 | Compression Plate | 316 Stainless Steel | | | Monel |
| 22 | Identification Tag | Stainless Steel | | | |
| 23 | Pop Rivet | Stainless Steel | | | |
| 29 | Bonnet Stud | ASTM A193 GR. B8, B8C, B8T or B8M, Monel | | | |
| 30 | Bonnet Stud Nut | ASTM A194 GR. 8B, 8CB, 8MB, 8TB, 8FB, Monel | | | |
| 31 | Disc Springs | Inconel | | | |
| 70 | Top Grounding Spring | Stainless Steel | | | |
| 71 | Bottom Grounding Spring | Inconel | | | |
| 72 | Retaining Ring | Stainless Steel | | | |
| 101 | Emission-Pak Stem Retainer | Carbon Steel ASTM A216 Type WCB | 316 Stainless Steel ASTM A351 Type CF8M | Alloy 20 ASTM A351 Type CN7M | Monel ASTM A494 M35-1 |
| 102 | Stud | ASTM A193 GR. B7, ASTM A193 GR. B8, B8C, B8T or B8M, Monel | | | |
| 103 | Spacer/Lantern Ring | 316 Stainless Steel, Monel, Alloy 20 | | | |
| 104 | Stem Seal | PTFE (w/ PTFE seats), TFM (w/ Xtreme & PFA seats) | | | |
| 105 | Inner Stem Retainer Seal | TFM | | | |
| 106 | Outer Stem Retainer Seal | Graphite | | | |
| 107 | Pipe Plug | Plastic | | | |
| 109 | Bearing Strip | PTFE | | | |
| 110 | Compression Ring | 316 Stainless Steel, Monel | | | |
| 111 | Hex Nut | ASTM A194 GR. 2H, ASTM A194 GR. 8B, 8CB, 8MB, 8TB, 8FB, Monel | | | |
| 112 | Warning Tag | Polyethylene | | | |

| BILLS OF MATERIALS AND PARTS LIST | | | | | |
|--|--------------------------------------|---|--|---------------------------------|------------------------------------|
| Non Fire- Tite 3" – 6" (DN 80 – 150) Standard Port Series 7000 Valves with <i>Emission- Pak</i> | | | | | |
| Part No. | Part Name | Body Material | | | |
| | | Carbon Steel (22) | 316 Stainless Steel (36) | Alloy 20 (35) | Monel (71) |
| 1 | Body | Carbon Steel ASTM A216 Type WCB | 316 Stainless Steel ASTM A351 Type CF8M | Alloy 20 ASTM A351 Type CN7M | Monel ASTM A494 M35-1 |
| 2 | Insert | Carbon Steel ASTM A216 Type WCB | 316 Stainless Steel ASTM A351 Type CF8M | Alloy 20 ASTM A351 Type CN7M | Monel ASTM A494 M35-1 |
| 3 | Ball | 316 Stainless Steel, Monel, Hastelloy C | | Alloy 20 | Monel, Hastelloy C as specified |
| 4 | Stem | 316 Stainless Steel, Monel, Hastelloy C | | Alloy 20 | Monel, Hastelloy C as specified |
| 5 | Seat | PTFE, <i>Xtreme</i> , PFA, PEEK ¹ & UHMWPE | | | |
| 6 | Body Seal | TFM (w/ PTFE, <i>Xtreme</i> , PFA seats) , UHMWPE (w/ UHMWPE seats), Graphite (w/ PEEK seats) | | | |
| 7 | Secondary Stem Seal | Graphite | | | |
| 13 | Thrust Bearing | PTFE, Filled PTFE | | | |
| 20 | Compression Plate | 316 Stainless Steel | | | Monel |
| 22 | Identification Tag | Stainless Steel | | | |
| 23 | Pop Rivet | Stainless Steel | | | |
| 24 | Thrust Bearing | PTFE (w/ PTFE seats), Filled PTFE (w/ <i>Xtreme</i> & PFA seats), PEEK (w/ PEEK seats), UHMWPE (w/ UHMWPE seats) | | | |
| 29 | Bonnet Stud | ASTM A193 GR. B8, B8C, B8T or B8M, Monel | | | |
| 30 | Bonnet Stud Nut | ASTM A194 GR. 8B, 8CB, 8MB, 8TB, 8FB, Monel | | | |
| 31 | Disc Springs | Inconel | | | |
| 70 | Top Grounding Spring | Stainless Steel | | | |
| 71 | Bottom Grounding Spring | Inconel | | | |
| 72 | Retaining Ring | Stainless Steel | | | |
| 101 | <i>Emission-Pak</i> Stem Retainer | Carbon Steel ASTM A216 Type WCB | 316 Stainless Steel ASTM A351 Type CF8M | Alloy 20 ASTM A351 Type CN7M | Monel ASTM A494 M35-1 |
| 102 | Stud | ASTM A193 GR. B7, ASTM A193 GR. B8, B8C, B8T or B8M, Monel | | | |
| 103 | Spacer/Lantern Ring | 316 Stainless Steel, Monel, Alloy 20 | | | |
| 104 | Stem Seal | PTFE (w/ PTFE seats), TFM (w/ <i>Xtreme</i> & PFA seats), UHMWPE (w/ UHMWPE seats), Graphite (w/ PEEK seats) | | | |
| 105 | Inner Stem Retainer Seal | TFM, PFA (w/ PFA Seats), UHMWPE (w/ UHMWPE seats) | | | |
| 106 | Outer Stem Retainer Seal | Graphite | | | |
| 107 | Pipe Plug | Plastic | | | |
| 109 | Bearing Strip | PTFE | | | |
| 110 | Compression Ring | 316 Stainless Steel, Monel | | | |
| 111 | Hex Nut | ASTM A194 GR. 2H, ASTM A194 GR. 8B, 8CB, 8MB, 8TB, 8FB, Monel | | | |
| 112 | Warning Tag | Polyethylene | | | |

Note 1: 17-4PH stem are required with PEEK seats

DIMENSIONS

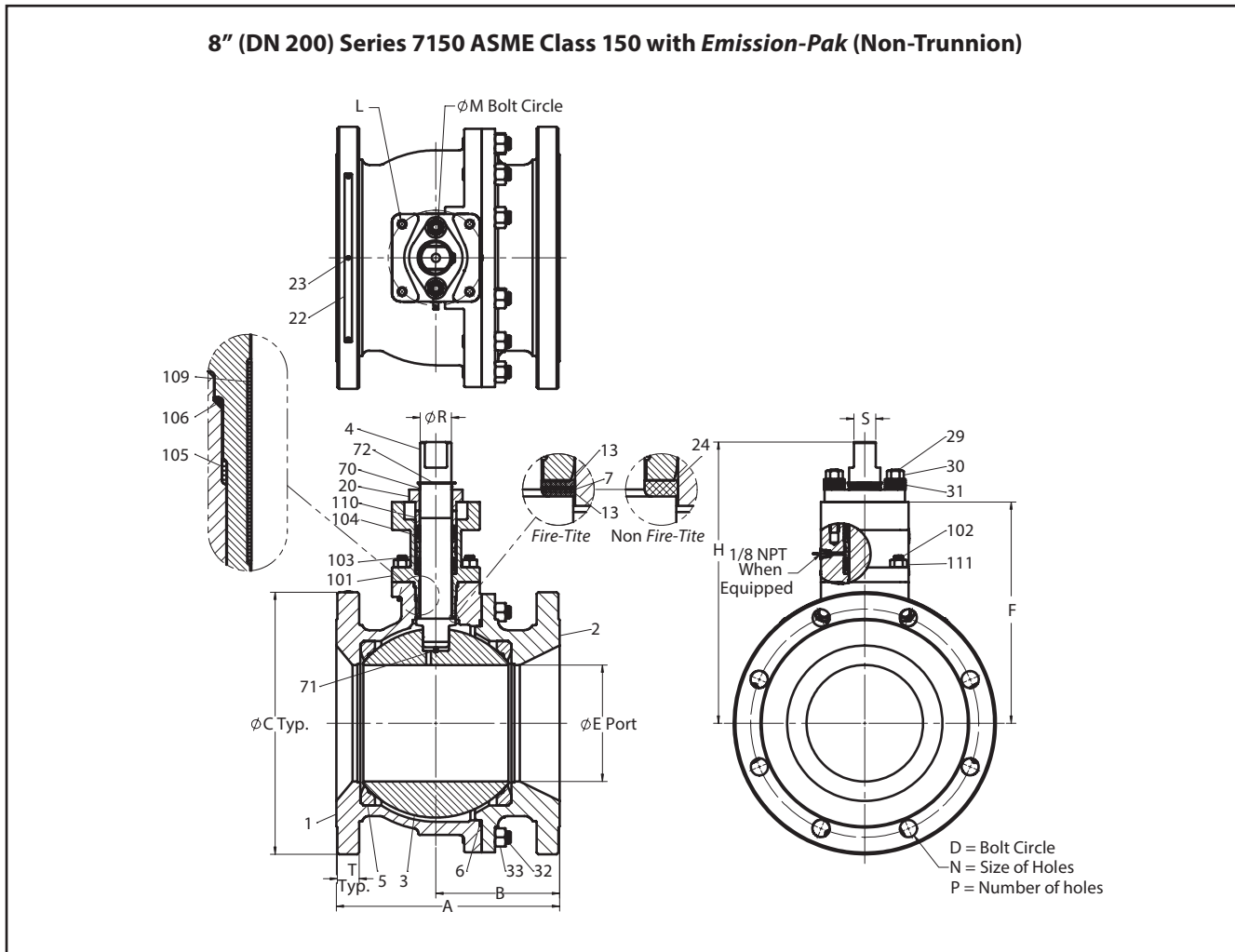

| Valve Size inches | Series 7150 Emission-Pak ASME Class 150 Approximate Dimensions - inches | | | | | | | | | | | | | | ISO Pattern | Weight lb |
|----------------------|---|------|-------|-------|------|-------|-------|-----|------|------|---|------|------|------|----------------|--------------|
| | A | B | C | D | E | F | H | L | M | N | P | R | S | T | | |
| 8 | 11.50 | 6.37 | 13.50 | 11.75 | 6.00 | 11.39 | 14.49 | M12 | 4.92 | 0.88 | 8 | 1.61 | 1.12 | 1.12 | F12 | 282 |

| Valve Size DN | Series 7150 Emission-Pak ASME Class 150 Approximate Dimensions - mm | | | | | | | | | | | | | | ISO Pattern | Weight kg |
|------------------|---|-----|-----|-----|---|-----|-----|-----|-----|----|---|----|----|----|----------------|--------------|
| | A | B | C | D | E | F | H | L | M | N | P | R | S | T | | |
| 200 | 292 | 162 | 343 | 298 | 6 | 289 | 368 | M12 | 125 | 22 | 8 | 41 | 28 | 28 | F12 | 128 |

| BILLS OF MATERIALS AND PARTS LIST | | | | | |
|--|--------------------------------------|---|--|------------------------------------|------------------------------------|
| Fire- Tite 8" (DN 200) Standard Port Series 7150 Valves with <i>Emission- Pak</i> | | | | | |
| Part No. | Part Name | Body Material | | | |
| | | Carbon Steel (22) | 316 Stainless Steel (36) | Alloy 20 (35) | Monel (71) |
| 1 | Body | Carbon Steel ASTM A216 Type WCB | 316 Stainless Steel ASTM A351 Type CF8M | Alloy 20 ASTM A351 Type CN7M | Monel ASTM A494 M35-1 |
| 2 | Body Cap | Carbon Steel ASTM A216 Type WCB | 316 Stainless Steel ASTM A351 Type CF8M | Alloy 20 ASTM A351 Type CN7M | Monel ASTM A494 M35-1 |
| 3 | Ball | 316 Stainless Steel, Monel, Hastelloy C | | Alloy 20 | Monel, Hastelloy C as specified |
| 4 | Stem | 316 Stainless Steel, Monel, Hastelloy C | | Alloy 20 | Monel, Hastelloy C as specified |
| 5 | Seat | PTFE, Xtreme, PFA | | | |
| 6 | Body Seal | Spiral Wound Graphite/316 Stainless Steel | | Spiral Wound Graphite/ Alloy 20 | Spiral Wound Graphite/ Monel |
| 7 | Secondary Stem Seal | Graphite | | | |
| 13 | Thrust Bearing | PTFE, Filled PTFE | | | |
| 20 | Compression Plate | 316 Stainless Steel | | | Monel |
| 22 | Identification Tag | Stainless Steel | | | |
| 23 | Pop Rivet | Stainless Steel | | | |
| 29 | Bonnet Stud | ASTM A193 GR. B8, B8C, B8T or B8M, Monel | | | |
| 30 | Bonnet Stud Nut | ASTM A194 GR. 8B, 8CB, 8MB, 8TB, 8FB, Monel | | | |
| 31 | Disc Springs | Inconel | | | |
| 32 | Body Stud | ASTM A193 GR. B8, B8C, B8T or B8M, Monel | | | |
| 33 | Body Stud Nut | ASTM A194 GR. 8B, 8CB, 8MB, 8TB, 8FB, Monel | | | |
| 70 | Top Grounding Spring | Stainless Steel | | | |
| 71 | Bottom Grounding Spring | Inconel | | | |
| 72 | Retaining Ring | Stainless Steel | | | |
| 101 | <i>Emission-Pak</i> Stem Retainer | Carbon Steel ASTM A216 Type WCB | 316 Stainless Steel ASTM A351 Type CF8M | Alloy 20 ASTM A351 Type CN7M | Monel ASTM A494 M35-1 |
| 102 | Stud | ASTM A193 GR. B7, ASTM A193 GR. B8, B8C, B8T or B8M, Monel | | | |
| 103 | Spacer/Lantern Ring | 316 Stainless Steel, Monel, Alloy 20 | | | |
| 104 | Stem Seal | PTFE (w/ PTFE seats), TFM (w/ Xtreme & PFA seats) | | | |
| 105 | Inner Stem Retainer Seal | TFM | | | |
| 106 | Outer Stem Retainer Seal | Graphite | | | |
| 107 | Pipe Plug | Plastic | | | |
| 109 | Bearing Strip | PTFE | | | |
| 110 | Compression Ring | 316 Stainless Steel, Monel | | | |
| 111 | Hex Nut | ASTM A194 GR. 2H, ASTM A194 GR. 8B, 8CB, 8MB, 8TB, 8FB, Monel | | | |
| 112 | Warning Tag | Polyethylene | | | |

| BILLS OF MATERIALS AND PARTS LIST | | | | | |
|---|----------------------------|---|---|------------------------------|---------------------------------|
| Non Fire- Tite 8" (DN 200) Standard Port Series 7150 Valves with Emission- Pak | | | | | |
| Part No. | Part Name | Body Material | | | |
| | | Carbon Steel (22) | 316 Stainless Steel (36) | Alloy 20 (35) | Monel (71) |
| 1 | Body | Carbon Steel ASTM A216 Type WCB | 316 Stainless Steel ASTM A351 Type CF8M | Alloy 20 ASTM A351 Type CN7M | Monel ASTM A494 M35-1 |
| 2 | Body Cap | Carbon Steel ASTM A216 Type WCB | 316 Stainless Steel ASTM A351 Type CF8M | Alloy 20 ASTM A351 Type CN7M | Monel ASTM A494 M35-1 |
| 3 | Ball | 316 Stainless Steel, Monel, Hastelloy C | | Alloy 20 | Monel, Hastelloy C as specified |
| 4 | Stem | 316 Stainless Steel, Monel, Hastelloy C | | Alloy 20 | Monel, Hastelloy C as specified |
| 5 | Seat | PTFE, Xtreme, PFA | | | |
| 6 | Body Seal | Spiral Wound PTFE/316 Stainless Steel | | Spiral Wound PTFE/ Alloy 20 | Spiral Wound PTFE/ Monel |
| 8 | Stem Seal | PTFE (w/ PTFE seats), TFM (w/ Xtreme & PFA seats) | | | |
| 13 | Thrust Bearing | PTFE, Filled PTFE | | | |
| 20 | Compression Plate | 316 Stainless Steel | | | Monel |
| 22 | Identification Tag | Stainless Steel | | | |
| 23 | Pop Rivet | Stainless Steel | | | |
| 29 | Bonnet Stud | ASTM A193 GR. B8, B8C, B8T or B8M, Monel | | | |
| 30 | Bonnet Stud Nut | ASTM A194 GR. 8B, 8CB, 8MB, 8TB, 8FB, Monel | | | |
| 31 | Disc Springs | Inconel | | | |
| 32 | Body Stud | ASTM A193 GR. B8, B8C, B8T or B8M, Monel | | | |
| 33 | Body Stud Nut | ASTM A194 GR. 8B, 8CB, 8MB, 8TB, 8FB, Monel | | | |
| 70 | Top Grounding Spring | Stainless Steel | | | |
| 71 | Bottom Grounding Spring | Inconel® | | | |
| 72 | Retaining Ring | Stainless Steel | | | |
| 101 | Emission-Pak Stem Retainer | Carbon Steel ASTM A216 Type WCB | 316 Stainless Steel ASTM A351 Type CF8M | Alloy 20 ASTM A351 Type CN7M | Monel ASTM A494 M35-1 |
| 102 | Stud | ASTM A193 GR. B7, ASTM A193 GR. B8, B8C, B8T or B8M, Monel | | | |
| 103 | Spacer/Lantern Ring | 316 Stainless Steel, Monel, Alloy 20 | | | |
| 104 | Stem Seal | PTFE (w/ PTFE seats), TFM (w/ Xtreme & PFA seats), UHMWPE (w/ UHMWPE seats), Graphite (w/ PEEK seats) | | | |
| 105 | Inner Stem Retainer Seal | TFM, PFA (w/ PFA Seats), UHMWPE (w/ UHMWPE seats) | | | |
| 106 | Outer Stem Retainer Seal | Graphite | | | |
| 107 | Pipe Plug | Plastic | | | |
| 109 | Bearing Strip | PTFE | | | |
| 110 | Compression Ring | 316 Stainless Steel, Monel | | | |
| 111 | Hex Nut | ASTM A194 GR. 2H, ASTM A194 GR. 8B, 8CB, 8MB, 8TB, 8FB, Monel | | | |
| 112 | Warning Tag | Polyethylene | | | |

EMISSION-PAK VALVE TORQUE DATA

Use these torque charts as a guide for actuator selection. Additional requirements may be imposed by media characteristics, trim, and frequency of valve operation. For clean lubricating fluid service, required torque for PTFE (T) and Xtreme (X) seated valves only may be reduced 20% when the valve is equipped with corrosion resistant trim. For difficult services such as slurries and semi-solids, and for oxygen, increase values by 50%. If in doubt, err on the side of safety by using a larger actuator than would normally be selected.

Torque output values and actuator selection tables for the different types of *Jamesbury* actuators are contained in the bulletins listed below.

| | |
|---------------------------------------|----------------|
| Manual Gear Actuators | A100-1 |
| B-Series Piston Actuators | 6B20 |
| <i>Quadra-Powr</i> X Spring Diaphragm | |
| Rotary Actuators | A110-4 |
| <i>Valv-Powr</i> Series VPVL | A111-3 |
| VPVL Stainless Steel | A111-4 |
| V-Series Electric Actuators | A200-1 |
| ADC-Series Electric Actuators | A201-1 |
| LC Series Electric Actuators | 202-1 & A203-1 |
| ESR-Series Electric Actuators | A204-1 |
| Q6-Series Electric Actuators | A205-1 |
| QX-Series Electric Actuators | A207-1 |

ANSI Class 150 and 300 Valve Torque Data

PTFE (T) Seated Valves

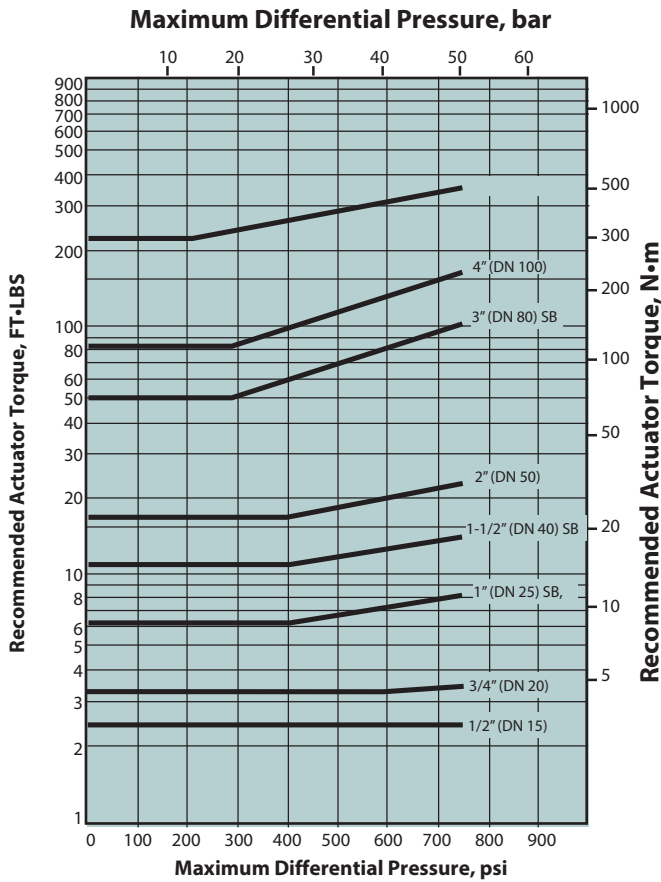

Xtreme (X) and TFM (Z) Seated Valves

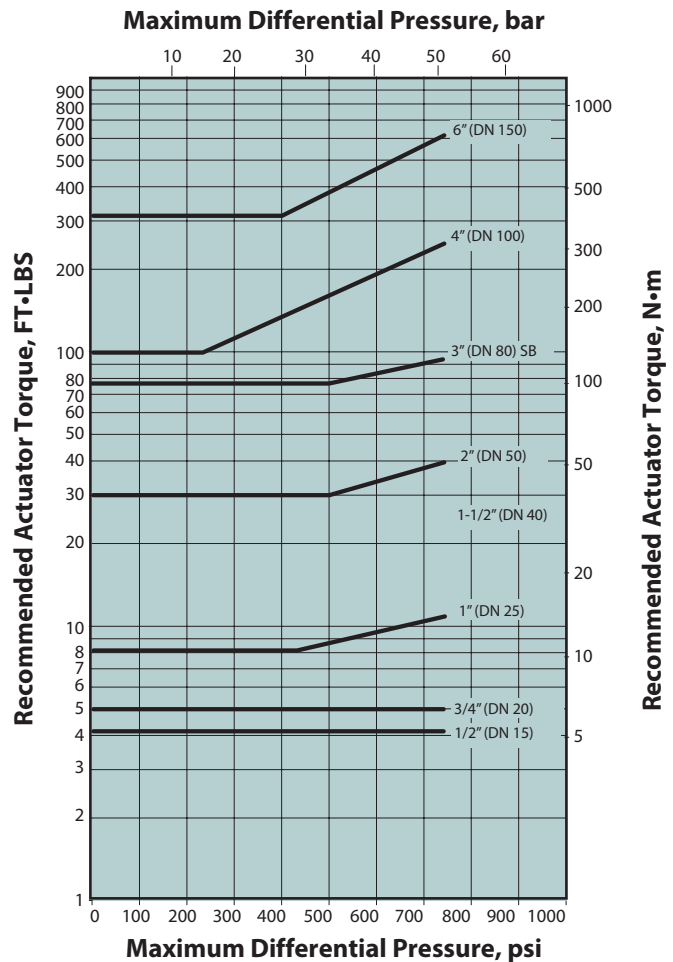

ACCESSORIES

Locking Devices

When safety measures are necessary, a reliable locking feature is standard to allow the valve to be padlocked in either the open or closed position.

Bonnet/Stem Extensions SE-096, 097 & 098

4" (102 mm) bonnet/stem extensions are available and are particularly useful for automated and manual products. Extensions can also be used to prevent interference between actuators and companion pipelines and equipment. They are ideal as extension that require locking lever or locking oval handle capability. Stainless steel construction is also available.

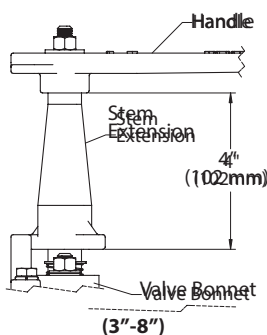
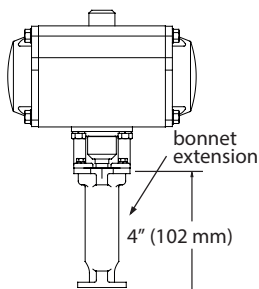

Stem Extensions

4" (102 mm) non-lockable stem extensions are available for manual valves. Extensions can also be used to prevent interference between companion pipelines and equipment. Compatible with all handle options. Stainless steel construction is also available.

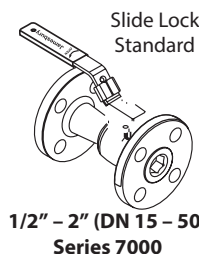
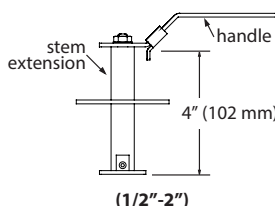

Round Handles

Series 7000 ball valves (1/2"-2") have optional round handles (non-lockable) available. To order handles separately, specify the part number shown in the accessories table below.

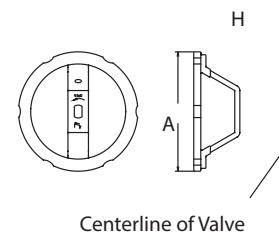

Oval handles with slide-lock

Optional oval handle (1/2" - 2") saves space and may be padlocked to retain the valve in the open or closed position. To order handles separately, specify the part number shown in the accessories table below.

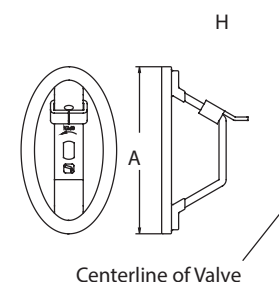

Cavity Fillers

Cavity fillers are available in non Trunnion 7000 series standard bore valves. The fillers are PTFE or Xtreme and used for sanitary applications and in processes where cross contamination is a concern. Food processing, pharma-chemicals, cosmetics, paints, solvents, finishes and dyes are typical applications where fillers are employed.

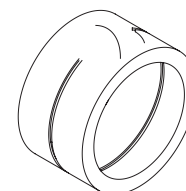

Accessory Table - inches (DN)

| Valve Size | Lever Handle | Locking Device | Stem Ext. | Bonnet/ Stem Ext. | Locking Oval | Round | Round/Oval Handle | | Allowable Max. Torque FT-LBS. (N-m) | |
|----------------------|--------------------|--------------------|-----------|-------------------|--------------|-------------|-------------------|--------------|-------------------------------------|---------|
| | | | | | | | Dimension A | Dimension H | Round | Oval |
| 1/2" (15) | Standard Equipment | Standard Equipment | SE-093 | SE-096 | 112-0108-30 | 112-0105-30 | 4.00 (101.6) | 2.96 (75.2) | 9 (12) | 9 (12) |
| 3/4" (20) | | | SE-094 | SE-096 | 112-0108-30 | 112-0105-30 | 4.00 (101.6) | 3.11 (79.0) | 9 (12) | 9 (12) |
| 1" (25) | | | SE-094 | SE-097 | 112-0109-30 | 112-0106-30 | 4.50 (114.3) | 3.70 (94.0) | 18 (24) | 18 (24) |
| 1-1/2" (40) | | | SE-095 | SE-098 | 112-0110-30 | 112-0107-30 | 5.75 (146.0) | 4.75 (120.7) | 25 (34) | 25 (34) |
| 2" (50) | | | SE-095 | SE-098 | 112-0110-30 | 112-0107-30 | 5.75 (146.0) | 4.94 (125.5) | 25 (34) | 25 (34) |
| 3" (80) | BHK-0070 | | SE-099 | SE-102 | | | | | | |
| 4" (100) 7150 | BHK-0070 | | SE-099 | SE-102 | | | | | | |
| 4" (100) 730S & 7300 | BHK-0071 | | SE-0100 | SE-103 | | | | | | |
| 6" (150) 7150 | BHK-0071 | | SE-0100 | SE-103 | | | | | | |
| 6" (150) 730S & 7300 | BHK-0072 | | SE-0101 | SE-104 | | | | | | |
| 8" (200) 7150 | BHK-0072 | | SE-0101 | SE-104 | | | | | | |
| | | | | | | | N/A | | | |

* For valves with PEEK(L) seats that require stem extensions use bonnet/stem extension SE-096, 097 or 098.

DIMENSIONS

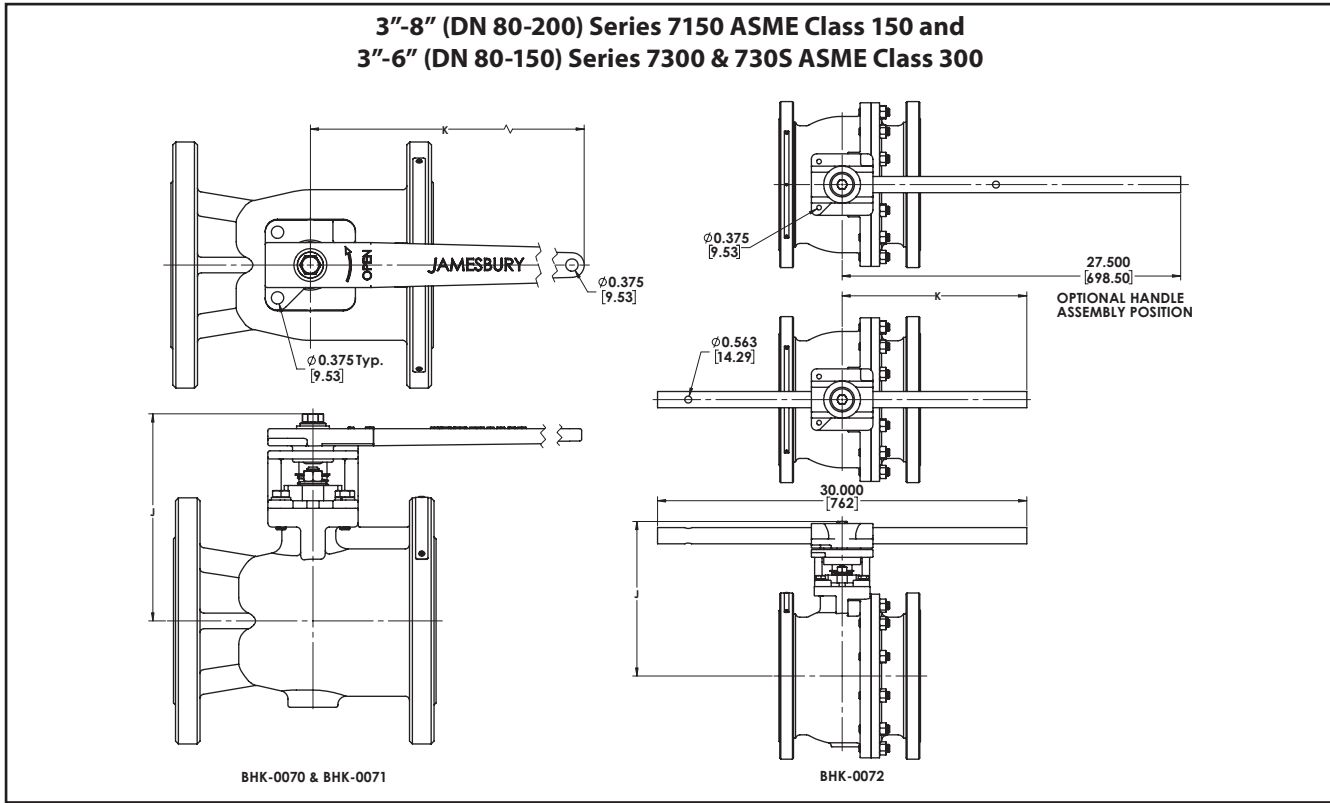

| Series 7150 ASME Class 150 Approximate Dimensions - inches | | | | | |
|--|-------------------|-------|-------|-------------|-----------|
| Valve Size inches | Handle Kit Number | J | K | ISO Pattern | Weight lb |
| 2 | BHK-0070 | 6.19 | 14.00 | F07 | 7 |
| 3 | BHK-0070 | 6.68 | 14.00 | F07 | 7 |
| 4 | BHK-0071 | 8.94 | 19.94 | F10 | 9 |
| 6 | BHK-0072 | 12.57 | 15.00 | F12 | 34 |

| Series 7150 ASME Class 150 Approximate Dimensions - mm | | | | | |
|--|-------------------|-----|-----|-------------|-----------|
| Valve Size DN | Handle Kit Number | J | K | ISO Pattern | Weight kg |
| 80 | BHK-0070 | 157 | 356 | F07 | 3 |
| 100 | BHK-0070 | 170 | 356 | F07 | 3 |
| 150 | BHK-0071 | 227 | 506 | F10 | 4 |
| 200 | BHK-0072 | 319 | 381 | F12 | 15 |

| Series 7300 & 730S ASME Class 300 Approximate Dimensions - inches | | | | | |
|---|-------------------|-------|-------|-------------|-----------|
| Valve Size inches | Handle Kit Number | J | K | ISO Pattern | Weight lb |
| 3 | BHK-0070 | 6.19 | 14.00 | F07 | 7 |
| 4 | BHK-0071 | 8.11 | 19.94 | F10 | 9 |
| 6 | BHK-0072 | 11.00 | 15.00 | F12 | 34 |

| Series 7300 & 730S ASME Class 150 Approximate Dimensions - mm | | | | | |
|---|-------------------|-----|-----|-------------|-----------|
| Valve Size DN | Handle Kit Number | J | K | ISO Pattern | Weight kg |
| 80 | BHK-0070 | 157 | 356 | F07 | 3 |
| 100 | BHK-0071 | 206 | 506 | F10 | 4 |
| 150 | BHK-0072 | 279 | 381 | F10 | 15 |

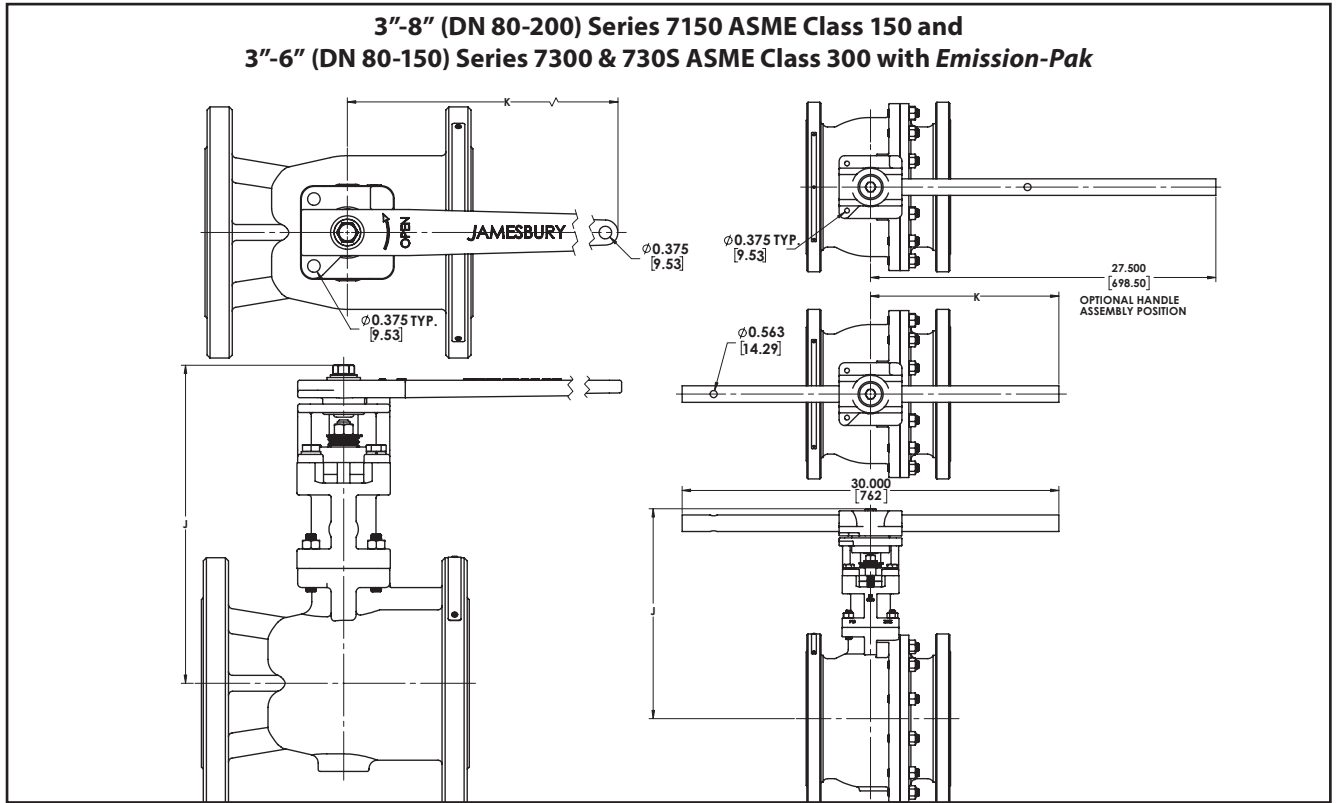

| Series 7150 ASME Class 150 Approximate Dimensions - inches | | | | | |
|--|-------------------|-------|-------|-------------|-----------|
| Valve Size inches | Handle Kit Number | J | K | ISO Pattern | Weight lb |
| 3 | BHK-0070 | 9.35 | 14.00 | F07 | 7 |
| 4 | BHK-0070 | 9.83 | 14.00 | F07 | 7 |
| 6 | BHK-0071 | 12.87 | 19.94 | F10 | 9 |
| 8 | BHK-0072 | 16.69 | 15.00 | F12 | 34 |

| Series 7150 ASME Class 150 Approximate Dimensions - mm | | | | | |
|--|-------------------|-----|-----|-------------|-----------|
| Valve Size DN | Handle Kit Number | J | K | ISO Pattern | Weight kg |
| 80 | BHK-0070 | 237 | 356 | F07 | 3 |
| 100 | BHK-0070 | 250 | 356 | F07 | 3 |
| 150 | BHK-0071 | 327 | 506 | F10 | 4 |
| 200 | BHK-0072 | 424 | 381 | F12 | 15 |

| Series 7300 & 730S ASME Class 300 Approximate Dimensions - inches | | | | | |
|---|-------------------|-------|-------|-------------|-----------|
| Valve Size inches | Handle Kit Number | J | K | ISO Pattern | Weight lb |
| 3 | BHK-0070 | 9.35 | 14.00 | F07 | 7 |
| 4 | BHK-0071 | 12.05 | 19.94 | F10 | 9 |
| 6 | BHK-0072 | 15.12 | 15.00 | F12 | 34 |

| Series 7300 & 730S ASME Class 300 Approximate Dimensions - mm | | | | | |
|---|-------------------|-----|-----|-------------|-----------|
| Valve Size DN | Handle Kit Number | J | K | ISO Pattern | Weight kg |
| 80 | BHK-0070 | 237 | 356 | F07 | 3 |
| 100 | BHK-0071 | 306 | 506 | F10 | 4 |
| 150 | BHK-0072 | 384 | 381 | F12 | 15 |

WARNING:

As the use of the valve is application specific, a number of factors should be taken into account when selecting a valve for a given application. Therefore, some of the situations in which the valves are used are outside the scope of this manual. If you have any questions concerning the use, application or compatibility of the valve with the intended service, contact Metso for more information.

HOW TO ORDER

EXAMPLE: A 2" ASME Class 300 short design valve (730S) in *Fire-Tite* design with raised-face flanges (31), carbon steel body (22), and 316 stainless steel trim (36), with *Xtreme* seats (XTZ) and molecularly enhanced PTFE stem seals is written: 2" 730S-31-2236XTZ1.

| | | | | | | | |
|----------|----------|----------|----------|----------|----------|----------|----------|
| 1 | 2 | 3 | 4 | 5 | 6 | 7 | 8 |
| 2" | 7150 | - | 31 | 22 | 36 | XTZ | 1 |

| 1 | Size | | |
|-------------------|----------------|--------------|--------------|
| 1/2" to 20" | 1/2" (DN 15) | 3" (DN 80) | 12" (DN 300) |
| | 3/4" (DN 20) | 4" (DN 100) | 14" (DN 350) |
| | 1" (DN 25) | 6" (DN 150) | 16" (DN 400) |
| | 1-1/2" (DN 40) | 8" (DN 200) | 18" (DN 450) |
| | 2" (DN 50) | 10" (DN 250) | 20" (DN 500) |

| 2 | Valve Series & Style | Size Range |
|----------------|-------------------------|--------------------------|
| 7150 | Reduced Bore Class 150 | 1/2" – 20" (DN 15 – 500) |
| 7180 | Reduced Bore Class 150* | 1/2" – 20" (DN 15 – 500) |
| 7300** | Reduced Bore Class 300 | 1/2" – 20" (DN 15 – 500) |
| 7380** | Reduced Bore Class 300* | 1/2" – 20" (DN 15 – 500) |
| 730S*** | Reduced Bore Class 300 | 1/2" – 12" (DN 15 – 300) |
| 738S** | Reduced Bore Class 300* | 1/2" – 12" (DN 15 – 300) |

* Metric units on nameplate. Includes static grounding. Valves larger than 1" (DN 25) are CE marked.

** 18" (DN 450) Only available as 7300 or 7380.

*** Special short pattern for the 730S or 738S uses a ASME Class 150 face to face.

| 3 | Special Construction | |
|----------------------------|---|--|
| — | Standard (no entry) | |
| C | Chlorine | |
| DBB | Double Block and Bleed | |
| DT | 125 RMS Flange Finish | |
| O | Oxygen | |
| Q | PTFE Cavity Filler | |
| STG | Static Ground (1/2" – 1-1/2" 9000) (Not for <i>Emission-Pak</i>) | |
| ST | Top Ground (1/2" – 1-1/2" 9000) (Not for <i>Emission-Pak</i>) | |
| V | High Vacuum | |
| VC | High Vacuum Certified | |
| <i>Emission-Pak</i> Coding | | |
| LA | Standard w/o leakoff | 1/2"-8" (DN 15 – 200) 7150/7180 1/2"-6" (DN 15 – 150) 7300/730S/ 7380/738S |
| LL | Standard w/ leakoff | |
| LC | Chlorine w/o leakoff | |
| L1 | Chlorine w/ leakoff | |
| L2 | Static Ground w/o leakoff (1/2" – 2" 7000 ONLY) | |
| L3 | Static Ground w/ leakoff (1/2" – 2" 7000 ONLY) | |
| LV | High Vacuum w/o leakoff | |
| LB | High Vacuum w/ leakoff | |
| LW | High Vacuum Certified w/o leakoff | |
| LJ | High Vacuum Certified w/ leakoff | |
| LX | Oxygen w/o leakoff | |
| LG | Oxygen w/ leakoff | |

| 4 | End Connection | Size Range |
|-----------|---|---|
| 11 | Raised Face, Non- <i>Fire-Tite</i> , Non-Trunnion | 1/2 – 10" (DN 15 – 250) |
| 31 | Raised Face, <i>Fire-Tite</i> , Non-Trunnion | 1/2 – 10" (DN 15 – 250) |
| 51 | Raised Face, Non- <i>Fire-Tite</i> , Non-Trunnion | 8 - 20" (DN 300 - 500) Class 150 6 - 20" (DN 300 - 500) Class 300 |
| 71 | Raised Face, <i>Fire-Tite</i> , Trunnion | 10 – 20" (DN 200 – 500) Class 150 8 – 20" (DN 250 – 500) Class 300 |

| 5 | Body Material* |
|-----------------------|------------------------|
| 22⁵ | Carbon Steel (WCB) |
| 28 | Carbon Steel (LCC) |
| 35 | Alloy 20 (CN7M) |
| 36⁵ | Stainless Steel (CF8M) |
| 71⁵ | Monel |

* Other materials available upon request

| 6 | Ball & Stem Materials* | |
|-----------------------|------------------------|----------------------------|
| 35 | Alloy 20 (CN7M) | |
| 36⁵ | Stainless Steel (CF8M) | |
| 71⁵ | Monel & K Monel | |
| 73 | Hastelloy C | |
| HB⁵ | 316 SS & 17-4PH | Required for seat code LGG |
| 00 | Same as body | Carbon steel not available |

* Other materials available upon request

| 7 | Seat Material* | Available Sizes |
|--------------------------|---------------------|--------------------------|
| XTZ | <i>Xtreme</i> | All |
| BTT | PFA | 1/2 – 8" (DN 15 – 200) |
| LGG^{†12} | PEEK | 1/2 – 6" (DN 15 – 150) |
| MBT¹ | Barrier Filled PTFE | 4" – 13" (DN 100 – 300) |
| TTT | PTFE | All |
| UUU¹ | UHMWPE | 1/2 – 10" (DN 15 – 250) |
| ZTT | TFM | 1/2" – 10" (DN 15 – 250) |

* Other materials available upon request

† Requires 17-4PH Stem

1 Non-*Fire-Tite* only

2 Not a self relieving seat

| 8 | Valve Body Bolting Materials | | Valve Gland Bolting Materials | |
|---|---|--------------------------------------|--|--------------------------------------|
| | Studs | Nuts | Bolts/Studs | Nuts |
| 1 | ASTM A193 Gr. B7 | ASTM A194 Gr. 2H or 2HB | ASTM A193 Gr. B8, B8C, B8M or B8T, Class 2 | ASTM A194 Gr. 8B, 8CB, 8MB, 8T8, 8FB |
| 2 | ASTM A193 Gr. B8, B8C, B8M or B8T Class 2 | ASTM A194 Gr. 8B, 8CB, 8MB, 8T8, 8FB | ASTM A193 Gr. B8, B8C, B8M or B8T, Class 2 | ASTM A194 Gr. 8B, 8CB, 8MB, 8T8, 8FB |
| 4 | K-Monel | K-Monel | K-Monel | K-Monel |
| 5 | ASTM A193 Gr. B7M | ASTM A194 Gr. 2HM | ASTM A193 Gr. B8, B8C, B8M or B8T, Class 2 | ASTM A194 Gr. 8B, 8CB, 8MB, 8T8, 8FB |
| H | Alloy 20 | Alloy 20 | Alloy 20 | Alloy 20 |

* Other materials available upon request

** Required for compliance to NACE for 2" and larger (if buried or insulated)

4 1-1/2" and smaller NACE compatibility (if buried or insulated)

5 Material meets NACE requirements for sour environments. For valves to be in full compliance with NACE, both the body (sign #5) and trim (sign #6) must meet the NACE requirements.

| 9 | Model* |
|---|--|
| A | 1/2" – 2" (DN 15 – 50) 7000 (Non-Emission-Pak) 8" (DN 200) 7300, 7380, 730S, 738S 10" (DN 250) 7000 12" – 20" (DN 300 – 500) 7000 |
| C | 1/2" – 2" (DN 15 – 50) 7000 (Emission-Pak) 3" – 8" 7150, 7180 (Non- Emission-Pak) 3" – 6" 7300, 7380, 730S, 738S (Non- Emission-Pak) 3" – 8" 7150, 7180 (Emission-Pak) 3" – 6" 7300, 7380, 730S, 738S (Emission-Pak) |

* Model Code not required when ordering

Hastelloy is a registered trademark of Haynes International, Inc.
Monel is a registered trademark of Special Materials Corp.
Inconel is a registered trademark of Special Materials Corp.

STANDARDS AND SPECIFICATIONS

The Company

ISO 9001 – 2015

Pressure Equipment Directive 2014/68/EU

Available Standards

| | |
|--|--|
| API 598 | American Petroleum Institute - Valve Inspection and testing |
| API 607 | American Petroleum Institute - Fire Test for Soft Seated Valves |
| API 608 | Metal Ball Valves Used in On-Off Service that have Butt-welded or Flanged Ends |
| ASME B16.10 | American National Standard - Face-to-Face and End-to-End Dimensions of Ferrous Valves |
| ASME B16.5 | American National Standard - Steel Pipe Flanges and Flanged Fittings |
| ASME B16.34 | American National Standard - Steel Valves - Flanged and Butt-welded End |
| ASME B31.1 | American National Standard - Power Piping |
| ASME B31.3 | American National Standard - Chemical Plant and Petroleum Refinery Piping |
| FCI 70-2 | American National Standard - For Control Valve Seat Leakage |
| ISO 15848-1 | Industrial Valves - Fugitive Emissions - Measurement, Test & Qualification Procedures |
| ISO 17292 | Metal Ball Valves for Petroleum, Petrochemical and Allied Industries |
| ISO 5752 | International Standard for Organization Metal Valves for use in Flanged Piping Systems |
| ISA 75.02 | Valve Sizing Coefficient Cv, Piping Geometry Factor Fp and Pressure Drop Limitation XT |
| ISA 75.19 | Hydrostatic Testing of Control Valves |
| ISO 5211 | Dimensions for Attachment of Actuators/Gear Boxes to Valves (ISO Mounting) |
| MSS SP-25 | Manufacturers Standardization Society - Standard Marking System for Valves |
| MSS-SP-55 | Manufacturers Standardization Society - Quality Standards for Steel Castings |
| MSS-SP-6 | Standard Finishes for Contact Faces of Pipe Flanges and Connecting-End Flanges of Valves and Fittings |
| MSS-SP-44 | Steel Pipe Line Flanges |
| MSS-SP-61 | Pressure Testing of Steel Valves |
| MSS SP-72 | Flanged or Butt and Weld End Ball Valves Having Full or Reduced Bores for General Liquid and Gas Service |
| MSS SP-96 | Terminology for Valves and Fittings |
| 2014/68/EU | European Pressure Equipment Directive (PED) |
| MSS SP-53-1995 | Quality Standard For Steel Castings and Forgings for Valves, Flanges and Fittings and Other Piping Components-Magnetic Particle Examination Method |
| MSS SP-93-1987 | Quality Standard For Steel Castings and Forgings for Valves, Flanges and Fittings and Other Piping Components-Liquid Penetrant Method |
| NACE Standard MR0103 | National Association of Corrosion Engineers - Materials Resistant to Sulfide Stress Cracking in Corrosive Petroleum Refining Environments |
| NACE Standard MR0175 | National Association of Corrosion Engineers - Materials For Use In H ₂ S- Containing Environments In Oil And Gas Production |
| Factory Mutual (FM) | Figure 1052 Gas and Oil Shutoff Valves. |
| Factory Mutual (FM) | Figure 1051 Supervisory Cock Valves, Electric Interlocking Fuel Gas and Fuel Oil Cocks. |
| CSA | Figure 1057/1056 Gas Shut-Off and Vent Valves. |
| Factory Mutual (FM) | Figure 1075 Emergency Shut-Off and Fire-Safe Valves. |
| CSA | CSA 3.16 |
| EN 161/264 | Automatic Shut-Off Valves for Gas Burners and Gas Appliances |
| Underwriter Laboratory (UL) | Categories MHKZ, YQAR, YRBX, YRPV, YSDT. |
| Underwriter's Laboratories of Canada (ULC) | Categories YSDT7 & YRPV7 |

Subject to change without prior notice.

Metso Flow Control Inc.

Europe, Vanha Porvoontie 229, P.O. Box 304, FI-01301 VANTAA, Finland.
Tel. +358 20 483 150. Fax +358 20 483 151

North America, 44 Bowditch Drive, P.O. Box 8044, Shrewsbury, MA 01545, USA.
Tel. +1 508 852 0200. Fax +1 508 852 8172

South America, Av. Independência, 2500- Iporanga, 18087-101, Sorocaba-São Paulo, Brazil.
Tel. +55 15 2102 9700. Fax +55 15 2102 9748/49

Asia Pacific, 238B Thomson Road, #17-01 Novena Square Tower B, Singapore 307685.
Tel. +65 6511 1011. Fax +65 6250 0830

China, 11/F, China Youth Plaza, No.19 North Rd of East 3rd Ring Rd, Chaoyang District,
Beijing 100020, China. Tel. +86 10 6566 6600. Fax +86 10 6566 2583

Middle East, Roundabout 8, Unit AB-07, P.O. Box 17175, Jebel Ali Freezone, Dubai,
United Arab Emirates. Tel. +971 4 883 6974. Fax +971 4 883 6836

www.metso.com/valves

